



Premium-Zerspanungswerkzeuge

Dreh-, Fräs- und Bohrwerkzeuge für Wendeschneidplatten
Turning, milling and drilling tools for indexable inserts



Das Unternehmen

Die TAM-Firmengruppe wurde 1993 mit Firmensitz in Deutschland gegründet und hat sich heute mit der Marke GOLDBERG® hervorragend am Markt etabliert. Spezialisiert auf Zerspanungswerkzeuge steht sie dabei international für höchste Qualität und Präzision.

Unser Produktsortiment umfasst ein sehr umfangreiches Lieferprogramm an modernsten Zerspanungswerkzeugen für Dreh-, Fräs- und Bohroperationen für die Metall verarbeitende Industrie. Das erlaubt es, uns jeder spezifischen Aufgabe mit Hilfe neuester Technologien zu stellen und höchst flexibel auf Ihre spezifischen Wünsche einzugehen. Dabei sind wir stets am Puls der Zeit, offen für Innovationen und bekannt für die Lösung individueller Problemstellungen.

Wir sind mit den Anforderungen in der Metall verarbeitenden Industrie bestens vertraut. Sie als Kunde profitieren von einem hohen Maß an Fachkompetenz, das kontinuierlich in alle Lösungen einfließt – konsequent verstärkt durch ein internes Qualitätskontrollsystem, welches eine Performance für höchste Anforderungen gewährleistet. Ergebnis unserer innovativen Technik sind Produkte, die sich durch präzise Verarbeitung, eine einzigartige Verschleißfestigkeit und damit hervorragende Standzeiten Ihrer Werkzeuge auszeichnen. Ihr Vorteil: ein langjähriger Einsatz, der zu geringeren Werkzeugkosten und zu einer höheren Auslastung Ihrer Produktion führt.

Auch sind wir Ihr zuverlässiger Partner, wenn es um die Integration in Ihr Supply-Chain-Management geht: Unser eigens entwickeltes Programm GOLDBERG®-XPRESS CARGO dient der optimierten Zusammenarbeit mit unseren und Ihren Logistikpartnern und gewährleistet die termingenaue, zuverlässige Lieferung der Werkzeuge. Das steigert die Effizienz in Ihrer Logistik – Wartezeiten werden vermieden.

Neben einem Höchstmaß an Leistungsfähigkeit und Qualitätsniveau gehört selbstverständlich auch eine faire Preispolitik zu unseren Prioritäten.

Kontaktieren Sie uns – wir sind gespannt auf Ihre Herausforderungen!



The company

GOLDBERG® is a brand of TAM Group, that was founded in Germany in the year 1993. As a specialist for cutting tools, GOLDBERG® products are internationally recognized for high performance tooling.

The product range encompasses a huge variety of cutting tools for turning, milling and drilling operations for the metal working industry. All our innovations are introduced only after having passed the internal quality control system so that high performance can be guaranteed.

Your advantage: longer tool life that leads to lower tooling cost and a higher utilization of production capacity.

The focus on the latest technological developments as well as our customer oriented culture allow us to respond to our customers specific requirements so that engineering of custom made tools is also one of our areas of expertise.

Besides of highly innovative tools and an excellent customer service, a fair pricing policy is one of our priorities.

Contact us – We look forward to your challenges!

Kompetenz & Leistungsfähigkeit für höchste Anforderungen / *Competence and performance for highest requirements*

Inhaltsverzeichnis / *Contents*

Drehen/Turning – GOLDturn

Drehhalter für die Außenbearbeitung / Turning toolholders for external machining

T & C-System	S.6 - S.14
M-System	S.15 - S.17
S-System	S.18 - S.29
Drehhalter für Langdrehautomaten / Toolholders for automatic lathes	S.30 - S.33
P-System	S.34 - S.42

Drehhalter für die Innenbearbeitung / Turning toolholders for internal machining

T & C-System	S.44 - S.49
M-System	S.50 - S.54
S-System	S.55 - S.65
P-System	S.66 - S.70
Gewindedrehhalter / Threading toolholders	S.71 - S.74

Bohren/Drilling – GOLDdrilling

Kurzklemmhalter / Cartridges	S.75 - S.81
Wendeplattenbohrer / U-Drills for indexable inserts	S.82 - S.90

Fräsen/Milling – GOLDmilling

Einschraub- und Schaftfräswerkzeuge / Screw-in and end mills	S.91 - S.98
Eck- und Planmesserköpfe / Shoulder and face milling cutters	S.99 - S.108
Scheibenfräser / Slot disc milling	S.109
T-Nutenfräser / T-Slot milling cutters	S.110

Drehhalter für die Innen- und Außenbearbeitung/
Toolholders for internal and external machining



1

P 1	S 2	K 3	N 4	R 5
---------------	---------------	---------------	---------------	---------------

1 Art der Schneidplattenbefestigung / Type of insert mounting

von oben gespannt/ top clamping	von oben über die Bohrung gespannt/ top and hole clamping	von oben und über die Bohrung gespannt/ top and hole clamping	über die Bohrung gespannt/ hole clamping	über die Bohrung geschraubt/ screw clamping
C	T	M	P	S

2 Grundform der Wendeschneidplatte /
Basic shape of indexable insert

C	D	E	K
L	R	S	T
V	W	A	B
H	M	O	P

3 Anstellwinkel / Approach angle

B	D	E	F	G	J
K	L	M	N	R	S
T	V	Y	Z		

4 Freiwinkel der Wendeschneidplatte /
Indexable insert clearance angle

A	B	C
D	E	F
G	N	P

6 **25** **25** - **M** **12** **C**
6 **7** **8** **9** **10**

5 Drehhalterausführung /
Orientation of turning toolholder

L	N	R

6 Drehhalterhöhe (mm) /
Turning toolholder height (mm)

7 Schaftbreite /
Shank width

8 Drehhalterlänge (mm) /
Turning toolholder length (mm)

A - 32	H - 100	Q - 180	x-special
B - 40	J - 110	R - 200	
C - 50	K - 125	S - 250	
D - 60	L - 140	T - 300	
E - 70	M - 150	U - 350	
F - 80	N - 160	V - 400	
G - 90	P - 170	W - 450	

9 Länge der Schneidkante (mm) /
Length of cutting edge (mm)

A,B,K	C,D,E,M,V	H	L		
O	P	R	S	T	W

10 Spannpratze /
Clamping wedge

T & C-System Außendrehhalter / *T & C-System external toolholders*



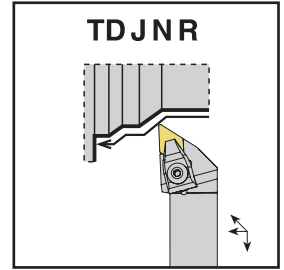
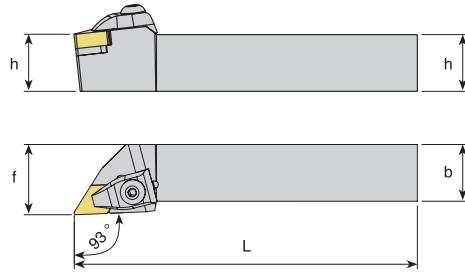

Bezeichnung Designation	Abmessungen (mm) Dimensions (mm)				Wendeplatte Insert	Ersatzteile Spare parts														
	h	b	L	f		Spannpratze (SP) Clamp	Schraube für SP Screw for clamp	Unterlage (UL) Shim	Schraube für UL Screw for shim	Druckfeder Pressure spring	Unterlegscheibe Washer	Winkelschlüssel Allen key								
TDJNR/L 1616 H 11	16	16	100	20																
2020 K 11	20	20	125	25									DNM. 11 04..	002001	003001	001028	004004	-		
2525 M 11	25	25	150	32																
2020 K 15	20	20	125	25	DNM. 15 06..	002002	003002	001030	004002	006001										
2525 M 15	25	25	150	32														005001	017003	
3232 P 15	32	32	170	40																
4040 S 15	40	40	250	50																
5050 S 15	50	50	250	63																

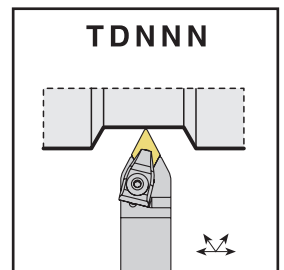
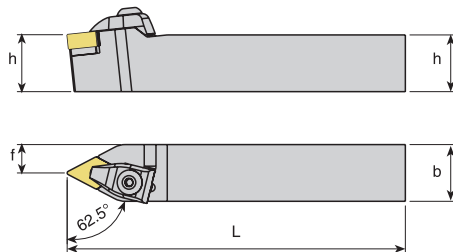

Bezeichnung Designation	Abmessungen (mm) Dimensions (mm)				Wendeplatte Insert	Ersatzteile Spare parts														
	h	b	L	f		Spannpratze (SP) Clamp	Schraube für SP Screw for clamp	Unterlage (UL) Shim	Schraube für UL Screw for shim	Druckfeder Pressure spring	Unterlegscheibe Washer	Winkelschlüssel Allen key								
TDNNN 1616 H 11	16	16	100	8																
2020 K 11	20	20	125	10									DNM. 11 04..	002001	003001	001028	004004	-		
2525 M 11	25	25	150	12.5																
2020 K 15	20	20	125	10	DNM. 15 06..	002002	003002	001030	004002	006001										
2525 M 15	25	25	150	12.5														005001	017003	
3232 P 15	32	32	170	16																
4040 S 15	40	40	250	20																
5050 S 15	50	50	250	25																

Bestellbeispiel/Ordering example: 1 Stk./pcs. TDJNR 1616 H11

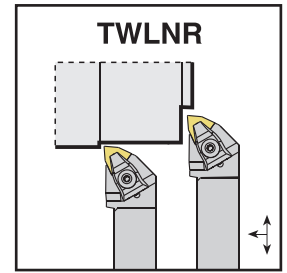
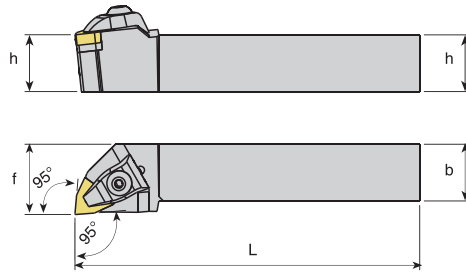
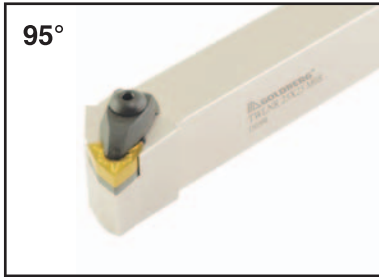

Bezeichnung Designation	Abmessungen (mm) Dimensions (mm)				Wendeplatte Insert	Ersatzteile Spare parts													
	h	b	L	f		Spannpratze (SP) Clamp	Schraube für SP Screw for clamp	Unterlage (UL) Shim	Schraube für UL Screw for shim	Druckfeder Pressure spring	Unterlegscheibe Washer	Winkelschlüssel Allen key							
TWLNR/L 1616 H 06	16	16	100	20															
2020 K 06	20	20	125	25									002001	003001	001018	004001	-		
2525 M06	25	25	150	32															
2020 K 08	20	20	125	25															
2525 M08	25	25	150	32									002002	003002	001017	004002	006001	005001	017003
3232 P 08	32	32	170	40															
4040 S 08	40	40	250	50															
5050 S 08	50	50	250	63															

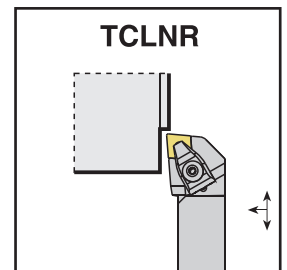
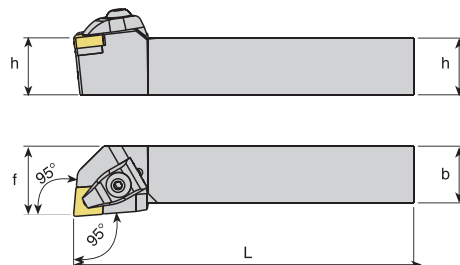

Bezeichnung Designation	Abmessungen (mm) Dimensions (mm)				Wendeplatte Insert	Ersatzteile Spare parts													
	h	b	L	f		Spannpratze (SP) Clamp	Schraube für SP Screw for clamp	Unterlage (UL) Shim	Schraube für UL Screw for shim	Druckfeder Pressure spring	Unterlegscheibe Washer	Winkelschlüssel Allen key							
TCLNR/L 2020 K 12	20	20	125	25															
2525 M12	25	25	150	32									002002	003002	001013	004002	006001	005001	017003
3232 P 12	32	32	170	40															
4040 S 12	40	40	250	50															
5050 S 12	50	50	250	63															
2525 M16	25	25	150	32															
3232 P 16	32	32	170	40									002004	003005	001014	003010	-	-	017004

Bestellbeispiel/Ordering example: 1 Stk./pcs. TCLNR 2020 K12

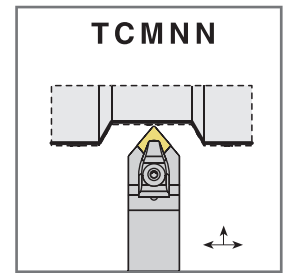
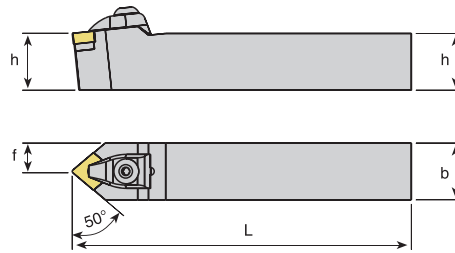

Bezeichnung Designation	Abmessungen (mm) Dimensions (mm)				Wendeplatte Insert	Ersatzteile Spare parts						
	h	b	L	f		Spannpratze (SP) Clamp	Schraube für SP Screw for clamp	Unterlage (UL) Shim	Schraube für UL Screw for shim	Druckfeder Pressure spring	Unterlegscheibe Washer	Winkelschlüssel Allen key
TCMNN 1616 H 12	16	16	100	8	CNM. 12 04..							
2020 K 12	20	20	125	10								
2525 M12	25	25	150	12.5								
3232 P 12	32	32	170	16								
3232 P 16	32	32	170	16	CNM. 16 06..							
4040 S 16	40	40	250	20								

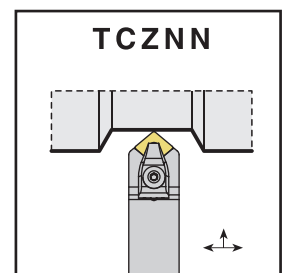
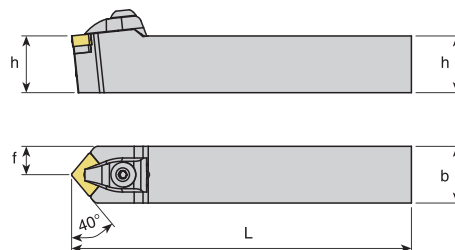

Bezeichnung Designation	Abmessungen (mm) Dimensions (mm)				Wendeplatte Insert	Ersatzteile Spare parts						
	h	b	L	f		Spannpratze (SP) Clamp	Schraube für SP Screw for clamp	Unterlage (UL) Shim	Schraube für UL Screw for shim	Druckfeder Pressure spring	Unterlegscheibe Washer	Winkelschlüssel Allen key
TCZNN 2020 K 12	20	20	125	10	CNM. 12 04..							
2525 M12	25	25	150	12.5								
3232 P 12	32	32	170	16								

Bestellbeispiel/Ordering example: 1 Stk./pcs. TCZNN 2020 K12

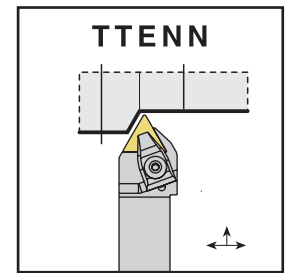
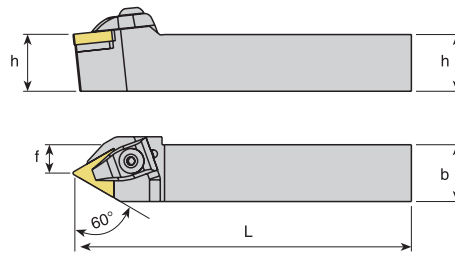

Bezeichnung Designation	Abmessungen (mm) Dimensions (mm)				Wendeplatte Insert	Ersatzteile Spare parts													
	h	b	L	f		Spannpratze (SP) Clamp	Schraube für SP Screw for clamp	Unterlage (UL) Shim	Schraube für UL Screw for shim	Druckfeder Pressure spring	Unterlegscheibe Washer	Winkelschlüssel Allen key							
TTENN 2020 K 16	20	20	125	10															
2525 M16	25	25	150	12.5									TNM. 16 04..	002001	003001	001002	004003	-	
3232 P 16	32	32	170	16															
2525 M22	25	25	150	12.5															
3232 P 22	32	32	170	16									TNM. 22 04..	002002	003002	001004	004002	006001	
4040 S 22	40	40	250	20															

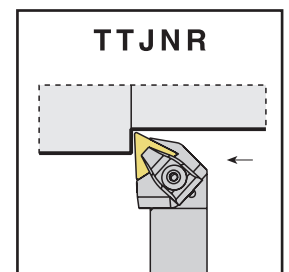
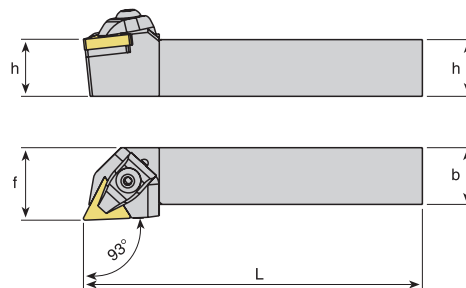

Bezeichnung Designation	Abmessungen (mm) Dimensions (mm)				Wendeplatte Insert	Ersatzteile Spare parts													
	h	b	L	f		Spannpratze (SP) Clamp	Schraube für SP Screw for clamp	Unterlage (UL) Shim	Schraube für UL Screw for shim	Druckfeder Pressure spring	Unterlegscheibe Washer	Winkelschlüssel Allen key							
TTJNR/L 2020 K 16	20	20	125	25															
2525 M16	25	25	150	32									TNM. 16 04..	002001	003001	001002	004003	-	
3232 P 16	32	32	170	40															
2525 M22	25	25	150	32															
3232 P 22	32	32	170	40									TNM. 22 04..	002002	003002	001004	004002	006001	
4040 S 22	40	40	250	50															

Bestellbeispiel/Ordering example: 1 Stk./pcs. TTJNR 2020 K16

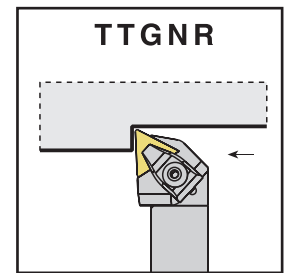
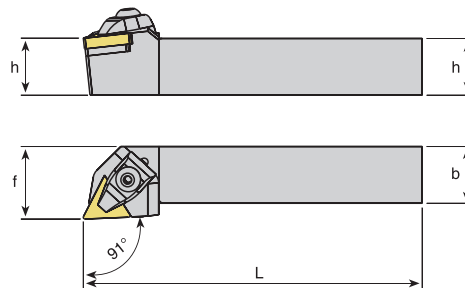
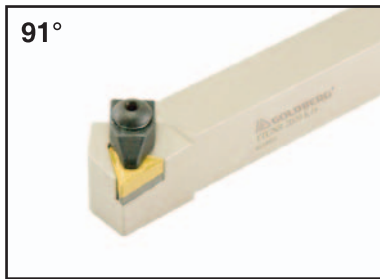

Bezeichnung Designation	Abmessungen (mm) Dimensions (mm)				Wendeplatte Insert	Ersatzteile Spare parts							
	h	b	L	f		Spannpratze (SP) Clamp	Schraube für SP Screw for clamp	Unterlage (UL) Shim	Schraube für UL Screw for shim	Druckfeder Pressure spring	Unterlegscheibe Washer	Winkelschlüssel Allen key	
TTG NR/L 2020 K 16	20	20	125	25			003001	001002	004003	-	005001	017003	
2525 M 16	25	25	150	TNM. 16 04..									002001
3232 P 16	32	32	170	40									003001
2525 M 22	25	25	150	32		003002	001004	004002	006001	005001	017003		
3232 P 22	32	32	170	40								TNM. 22 04..	002002
4040 S 22	40	40	250	50								003002	

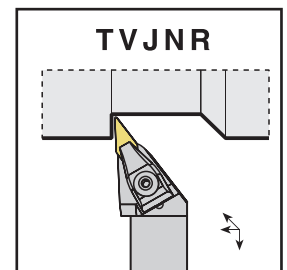
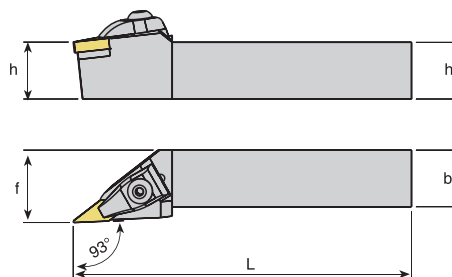

Bezeichnung Designation	Abmessungen (mm) Dimensions (mm)				Wendeplatte Insert	Ersatzteile Spare parts								
	h	b	L	f		Spannpratze (SP) Clamp	Schraube für SP Screw for clamp	Unterlage (UL) Shim	Schraube für UL Screw for shim	Druckfeder Pressure spring	Unterlegscheibe Washer	Winkelschlüssel Allen key		
TVJ NR/L 2020 K 16	20	20	125	25			003002	001032	004004	006001	005001	017003		
2525 M 16	25	25	150	32									VNM. 16 04..	002003
3232 P 16	32	32	170	40									003002	

Bestellbeispiel/Ordering example: 1 Stk./pcs. TVJNR 2020 K16

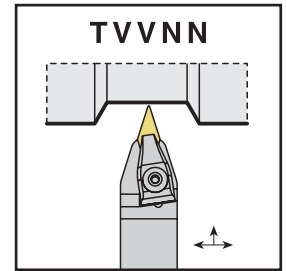
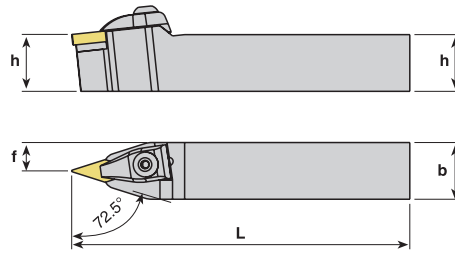
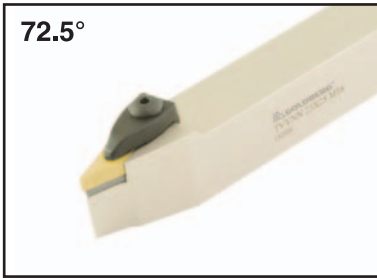

Bezeichnung Designation	Abmessungen (mm) Dimensions (mm)				Wendeplatte Insert	Ersatzteile Spare parts														
	h	b	L	f		Spannpratze (SP) Clamp	Schraube für SP Screw for clamp	Unterlage (UL) Shim	Schraube für UL Screw for shim	Druckfeder Pressure spring	Unterlegscheibe Washer	Winkelschlüssel Allen key								
TVVNN 2020 K 16	20	20	125	10																
2525 M 16	25	25	150	12,5									VNM. 16 04..	002003	003002	001032	004004	006001	005001	017003
3232 P 16	32	32	170	16																

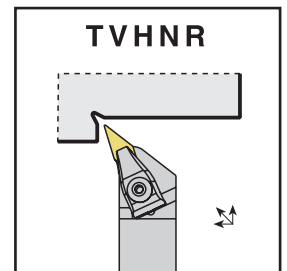
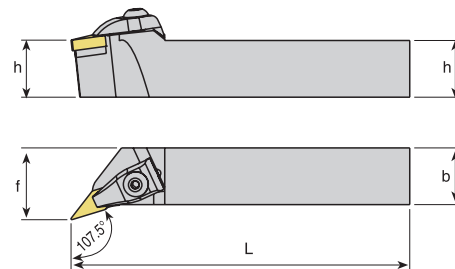

Bezeichnung Designation	Abmessungen (mm) Dimensions (mm)				Wendeplatte Insert	Ersatzteile Spare parts														
	h	b	L	f		Spannpratze (SP) Clamp	Schraube für SP Screw for clamp	Unterlage (UL) Shim	Schraube für UL Screw for shim	Druckfeder Pressure spring	Unterlegscheibe Washer	Winkelschlüssel Allen key								
TVHNR/L 2020 K 16	20	20	125	25																
2525 M 16	25	25	150	32									VNM. 16 04..	002003	003002	001032	004004	006001	005001	017003
3232 P 16	32	32	170	40																

Bestellbeispiel/Ordering Example: 1 Stk./pcs. TVHNR 2020 K16

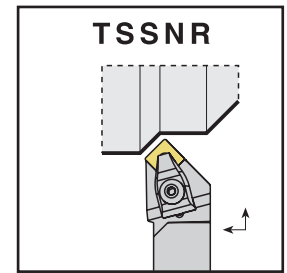
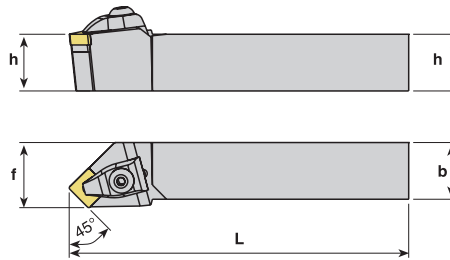

Bezeichnung Designation	Abmessungen (mm) Dimensions (mm)				Wendeplatte Insert	Ersatzteile Spare parts						
	h	b	L	f		Spannpratze (SP) Clamp	Schraube für SP Screw for clamp	Unterlage (UL) Shim	Schraube für UL Screw for shim	Druckfeder Pressure spring	Unterlegscheibe Washer	Winkelschlüssel Allen key
TSSNR/L2020 K 12	20	20	125	25	SNM. 12 04..							
2525 M 12	25	25	150	32								
3232 P 12	32	32	170	40								
2525 M 15	25	25	150	32	SNM. 15 06..					-	-	

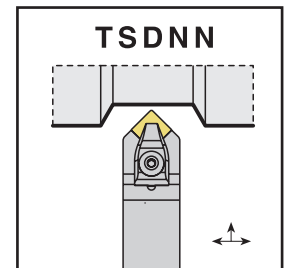
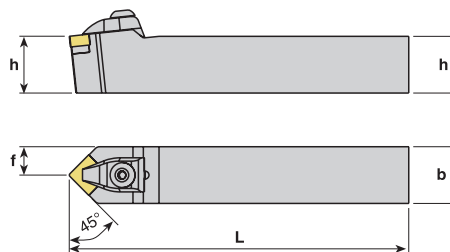

Bezeichnung Designation	Abmessungen (mm) Dimensions (mm)				Wendeplatte Insert	Ersatzteile Spare parts						
	h	b	L	f		Spannpratze (SP) Clamp	Schraube für SP Screw for clamp	Unterlage (UL) Shim	Schraube für UL Screw for shim	Druckfeder Pressure spring	Unterlegscheibe Washer	Winkelschlüssel Allen key
TSDNN 1616 H 12	16	16	100	8	SNM. 12 04..							
2020 K 12	20	20	125	10								
2525 M 12	25	25	150	12.5								
3232 P 12	32	32	170	16								
2525 M 15	25	25	150	12.5	SNM. 15 06..					-	-	
3232 P 15	32	32	170	16								
4040 S 15	40	40	250	20								

Bestellbeispiel/Ordering example: 1 Stk./pcs. TSDNN 1616 H12

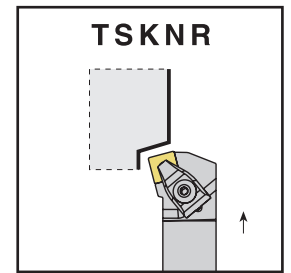
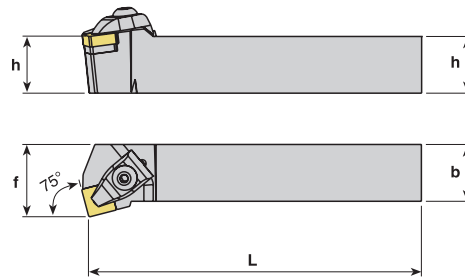

Bezeichnung Designation	Abmessungen (mm) Dimensions (mm)				Wendeplatte Insert	Ersatzteile Spare parts						
	h	b	L	f		Spannpratze (SP) Clamp	Schraube für SP Screw for clamp	Unterlage (UL) Shim	Schraube für UL Screw for shim	Druckfeder Pressure spring	Unterlegscheibe Washer	Winkelschlüssel Allen key
TSKNR/L 2020 K 12	20	20	125	25	SNM. 12 04.. 							
2525 M12	25	25	150	32		002002	003002	001023	004002	006001	005001	017003
3232 P 12	32	32	170	40								

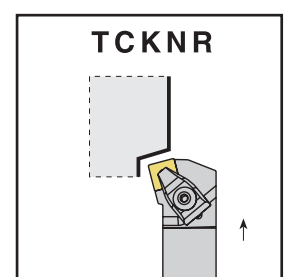
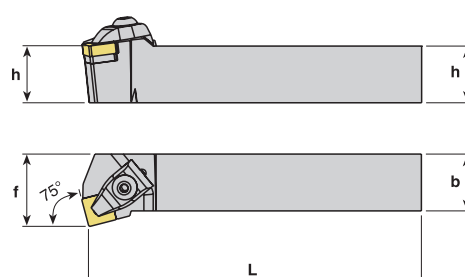
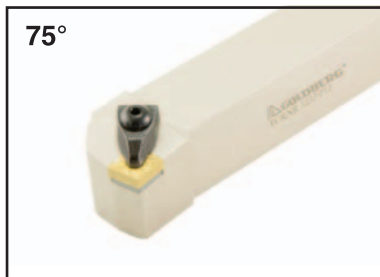

Bezeichnung Designation	Abmessungen (mm) Dimensions (mm)				Wendeplatte Insert	Ersatzteile Spare parts						
	h	b	L	f		Spannpratze (SP) Clamp	Schraube für SP Screw for clamp	Unterlage (UL) Shim	Schraube für UL Screw for shim	Druckfeder Pressure spring	Unterlegscheibe Washer	Winkelschlüssel Allen key
TCKNR/L 2020 K 12	20	20	125	25	CNM. 12 04.. 							
2525 M12	25	25	150	32		002002	003002	001013	004002	006001	005001	017003
3232 P 12	32	32	170	40								
2525 M16	25	25	150	32	CNM. 16 06.. 							
3232 P 16	32	32	170	40		002004	003005	001014	003010	-	-	017004

Bestellbeispiel/Ordering Example: 1 Stk./pcs. TCKNR 2020 K12

M-System Außendrehhalter / *M-System external toolholders*



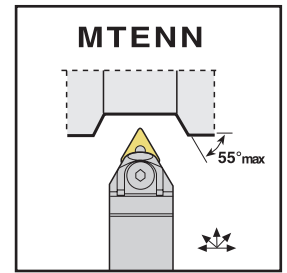
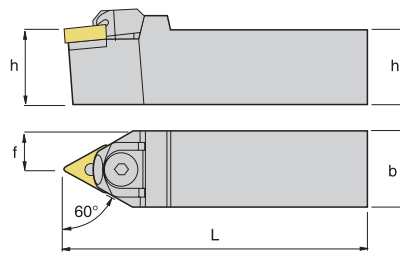
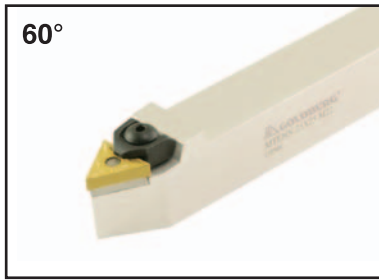

Bezeichnung Designation	Abmessungen (mm) Dimensions (mm)				Wendeplatte Insert	Ersatzteile Spare parts												
	h	b	L	f		Spannkittsatz (SKS) Wedge clamp	Schraube für SKS Screw for clamp	Unterlage Shim	Stift Pin	Unterlegscheibe Washer	Winkelschlüssel Allen key							
MTENN 2020 K 16	20	20	125	10														
2525 M 16	25	25	150	12.5								TNM. 16 04..	002008	003002	001002	007001	005001	017003
3232 P 16	32	32	170	16								TNM. 22 04..	002008	003002	001004	007002	005001	017003
2525 M 22	25	25	150	12.5														
3232 P 22	32	32	170	16														
4040 S 22	40	40	250	20														

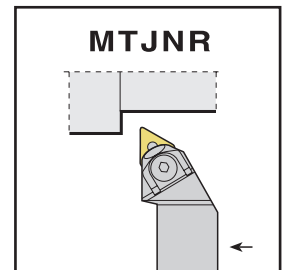
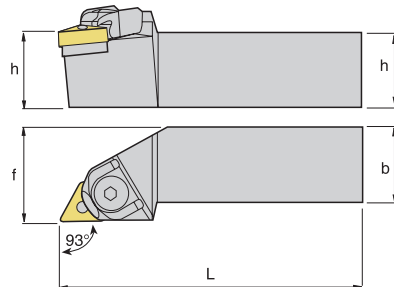

Bezeichnung Designation	Abmessungen (mm) Dimensions (mm)				Wendeplatte Insert	Ersatzteile Spare parts												
	h	b	L	f		Spannkittsatz (SKS) Wedge clamp	Schraube für SKS Screw for clamp	Unterlage Shim	Stift Pin	Unterlegscheibe Washer	Winkelschlüssel Allen key							
MTJNR/L 2020 K 16	20	20	125	25														
2525 M 16	25	25	150	32								TNM. 16 04..	002008	003002	001002	007001	005001	017003
3232 P 16	32	32	170	40								TNM. 22 04..	002008	003002	001004	007002	005001	017003
2525 M 22	25	25	150	32														
3232 P 22	32	32	170	40														
4040 S 22	40	40	250	50														

Bestellbeispiel/Ordering Example: 1 Stk/pcs. MTJNR 2020 K16

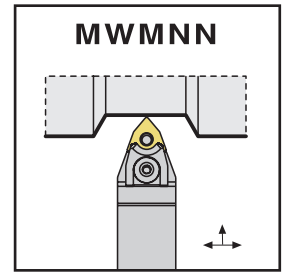
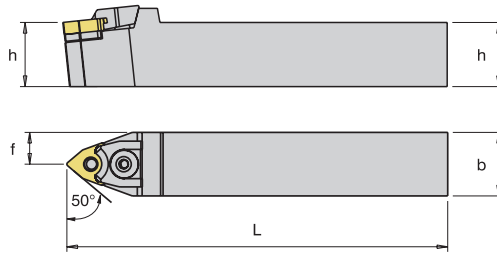
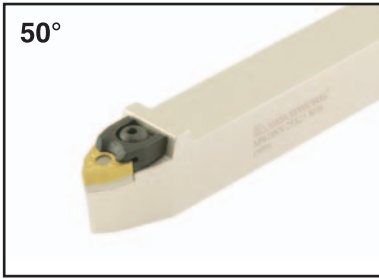

Bezeichnung Designation	Abmessungen (mm) Dimensions (mm)				Wendeplatte Insert	Ersatzteile Spare parts											
	h	b	L	f		Spannkaisatz (SKS) Wedge clamp	Schraube für SKS Screw for clamp	Unterlage Shim	Stift Pin	Unterlegscheibe Washer	Winkelschlüssel Allen key						
MWMNN 1616 H 06-Z	16	16	100	8													
2020 K 06-Z	20	20	125	10								WNM. 06 04..	002005	003004	-	007003	-
2525 M06-Z	25	25	150	12.5													
2020 K 08	20	20	125	10													
2525 M08	25	25	150	12.5								WNM. 08 04..	002009	003003	001017	007002	005001
3232 P 08	32	32	170	16													

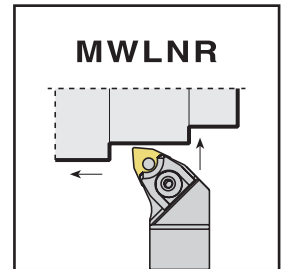
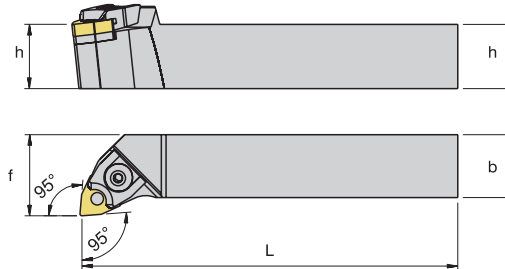

Bezeichnung Designation	Abmessungen (mm) Dimensions (mm)				Wendeplatte Insert	Ersatzteile Spare Parts											
	h	b	L	f		Spannkaisatz (SKS) Wedge clamp	Schraube für SKS Screw for clamp	Unterlage Shim	Stift Pin	Unterlegscheibe Washer	Winkelschlüssel Allen key						
MWLNR/L 1616 H 06-Z	16	16	100	20													
2020 K 06-Z	20	20	125	25								WNM. 06 04..	002005	003004	-	007003	-
2525 M06-Z	25	25	150	32													
2020 K 08	20	20	125	25													
2525 M08	25	25	150	32								WNM. 08 04..	002009	003003	001017	007002	005001
3232 P 08	32	32	170	40													

Bestellbeispiel/Ordering example: 1 Stk/pcs. MWLNR 1616 H06

S-System Außendrehhalter / *S-System external toolholders*



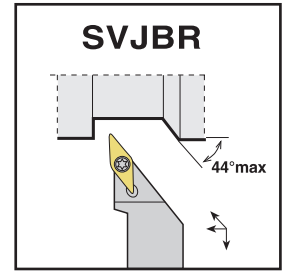
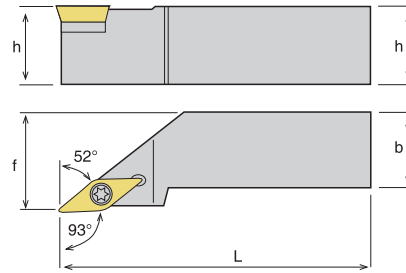

Bezeichnung Designation	Abmessungen (mm) Dimensions (mm)				Wendeplatte Insert	Ersatzteile Spare parts								
	h	b	L	f		Spannschraube für WPL Clamping screw for insert	Unterlage Shim	Schraube für Unterlage Screw for shim	Torx Schlüssel Torx key					
SVJBR/L 1212 F 11	12	12	80	16										
1616 H 11	16	16	100	20						VBM. 11 03..	011007	-	-	018003
2020 K 11	20	20	125	25										
2020 K 16	20	20	125	25										
2525 M 16	25	25	150	32						VBM. 16 04..	011042	001032	004006	018005
3232 P 16	32	32	170	40										

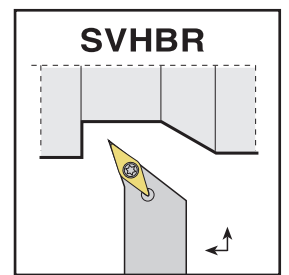
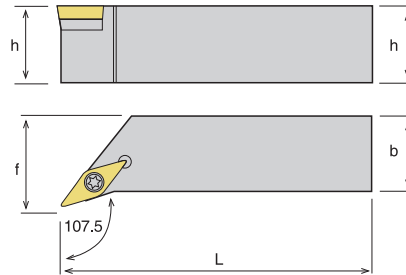

Bezeichnung Designation	Abmessungen (mm) Dimensions (mm)				Wendeplatte Insert	Ersatzteile Spare parts								
	h	b	L	f		Spannschraube für WPL Clamping screw for insert	Unterlage Shim	Schraube für Unterlage Screw for shim	Torx Schlüssel Torx key					
SVHBR/L 1212 F 11	12	12	80	16										
1616 H 11	16	16	100	20						VBM. 11 03..	011007	-	-	018003
2020 K 11	20	20	125	25										
2020 K 16	20	20	125	25										
2525 M 16	25	25	150	32						VBM. 16 04..	011042	001032	004006	018005
3232 P 16	32	32	170	40										

Bestellbeispiel/Ordering example: 1 Stk./pcs. SVHBR 1212.F11

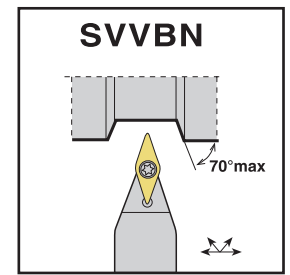
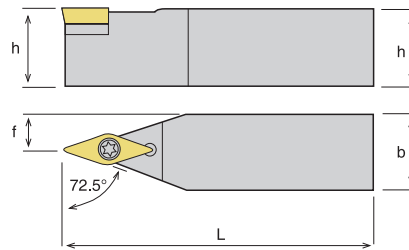



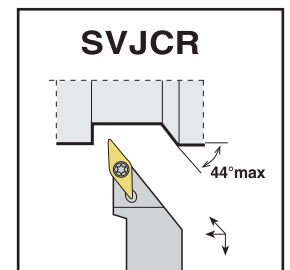
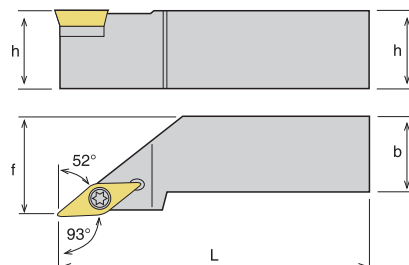





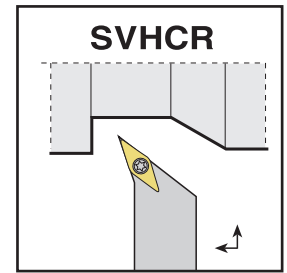
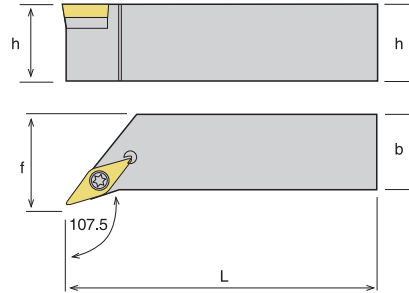

Bezeichnung Designation	Abmessungen (mm) Dimensions (mm)				Wendeplatte Insert	Ersatzteile Spare parts			
	h	b	L	f		Spannschraube für WPL Clamping screw for insert	Unterlage Shim	Schraube für Unterlage Screw for shim	Torx Schlüssel Torx key
SVVBN 1212 F 11	12	12	80	06			-	-	
1616 H 11	16	16	100	08					
2020 K 11	20	20	125	10					
2020 K 16	20	20	125	10			001032	004006	
2525 M 16	25	25	150	12.5					
3232 P 16	32	32	170	16					









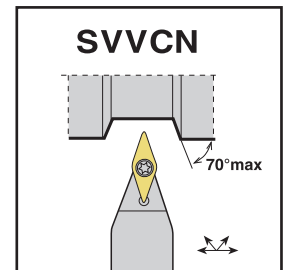
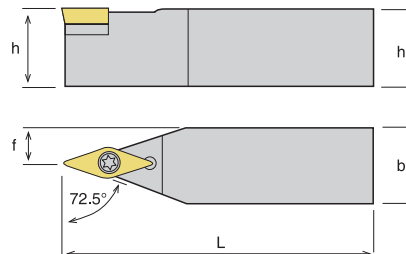

Bezeichnung Designation	Abmessungen (mm) Dimensions (mm)				Wendeplatte Insert	Ersatzteile Spare parts			
	h	b	L	f		Spannschraube für WPL Clamping screw for insert	Unterlage Shim	Schraube für Unterlage Screw for shim	Torx Schlüssel Torx key
SVJCR/L 1212 F 11	12	12	80	16			-	-	
1616 H 11	16	16	100	20					
2020 K 11	20	20	125	25					
2020 K 16	20	20	125	25			001032	004006	
2525 M 16	25	25	150	32					
3232 P 16	32	32	170	40					

Bestellbeispiel/Ordering example: 1 Stk/pcs. SVJCR 1212 F11

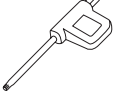

Bezeichnung Designation	Abmessungen (mm) Dimensions (mm)				Wendeplatte Insert	Ersatzteile Spare parts								
	h	b	L	f			Spannschraube für WPL Clamping screw for insert	Unterlage Shim	Schraube für Unterlage Screw for shim	Torx Schlüssel Torx key				
											h	b	L	f
SVHCR/L1212 F 11	12	12	80	16			-							
1616 H 11	16	16	100	20						VCM. 11 03..	011007	-	-	018003
2020 K 11	20	20	125	25						VCM. 16 04..	011042	001032	004006	018005
2020 K 16	20	20	125	25			-							
2525 M16	25	25	150	32						VCM. 16 04..	011042	001032	004006	018005
3232 P 16	32	32	170	40						VCM. 16 04..	011042	001032	004006	018005

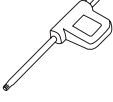

Bezeichnung Designation	Abmessungen (mm) Dimensions (mm)				Wendeplatte Insert	Ersatzteile Spare parts								
	h	b	L	f			Spannschraube für WPL Clamping screw for insert	Unterlage Shim	Schraube für Unterlage Screw for shim	Torx Schlüssel Torx key				
											h	b	L	f
SVVCN 1212 F 11	12	12	80	06			-							
1616 H 11	16	16	100	08						VCM. 11 03..	011007	-	-	018003
2020 K 11	20	20	125	10						VCM. 16 04..	011042	001032	004006	018005
2020 K 16	20	20	125	10			-							
2525 M16	25	25	150	12.5						VCM. 16 04..	011042	001032	004006	018005
3232 P 16	32	32	170	16						VCM. 16 04..	011042	001032	004006	018005

Bestellbeispiel/Ordering example: 1 Stk/pcs. SVVCN 1212 F11

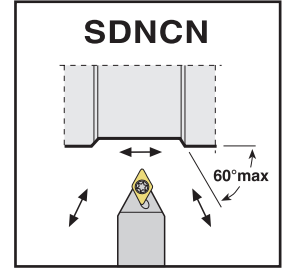
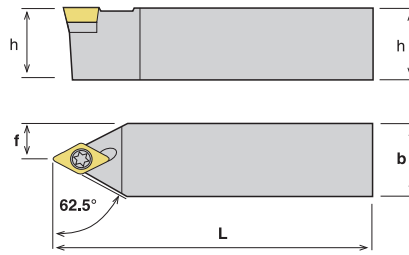

Bezeichnung Designation	Abmessungen (mm) Dimensions (mm)				Wendeplatte Insert	Ersatzteile Spare parts			
	h	b	L	f		Spannschraube für WPL Clamping screw for insert	Unterlage Shim	Schraube für Unterlage Screw for shim	Torx Schlüssel Torx key
SDNCN 0808 E 07	08	08	70	04			-		
1010 E 07	10	10	70	05					
1212 F 07	12	12	80	06					
1616 H 07	16	16	100	08					
1616 H 11	16	16	100	08			001028		
2020 K 11	20	20	125	10					
2525 M 11	25	25	150	12.5					
3232 P 11	32	32	170	16					

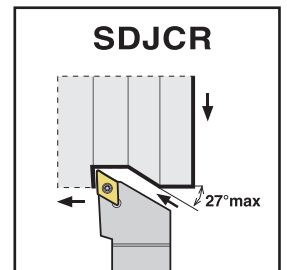
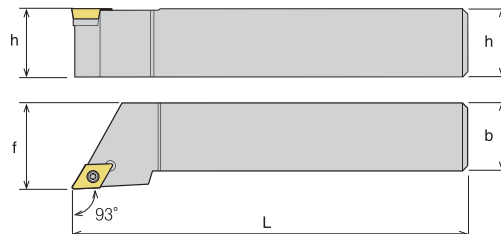

Bezeichnung Designation	Abmessungen (mm) Dimensions (mm)				Wendeplatte Insert	Ersatzteile Spare parts			
	h	b	L	f		Spannschraube für WPL Clamping screw for insert	Unterlage (UL) Shim	Schraube für Unterlage Screw for shim	Torx Schlüssel Torx key
SDJCR/L 0808 E 07	08	08	70	10			-		
1010 E 07	10	10	70	12					
1212 F 07	12	12	80	16					
1616 H 07	16	16	100	20					
1616 H 11	16	16	100	20			001028		
2020 K 11	20	20	125	25					
2525 M 11	25	25	150	32					
3232 P 11	32	32	170	40					

Bestellbeispiel/Ordering Example: 1 Stk/pcs. SDJCR 0808 E07

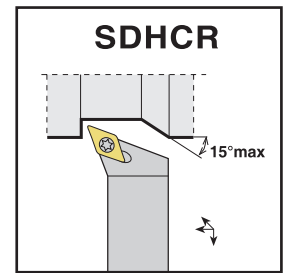
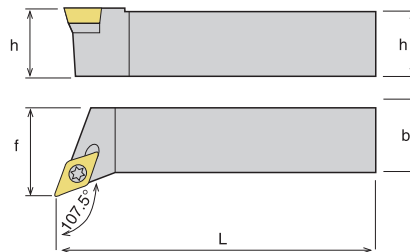

Bezeichnung Designation	Abmessungen (mm) Dimensions (mm)				Wendeplatte Insert	Ersatzteile Spare parts			
	h	b	L	f		Spannschraube für WPL Clamping screw for insert	Unterlage Shim	Schraube für Unterlage Screw for shim	Torx Schlüssel Torx key
SDHCR/L 0808 E 07	08	08	70	10			-	-	
1010 E 07	10	10	70	12					
1212 F 07	12	12	80	16					
1616 H 07	16	16	100	20					
1616 H 11	16	16	100	20			001028	004006	
2020 K 11	20	20	125	25					
2525 M 11	25	25	150	32					
3232 P 11	32	32	170	40					

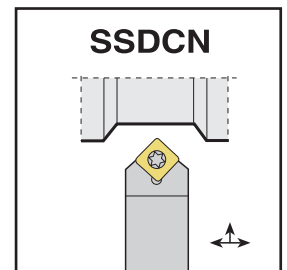
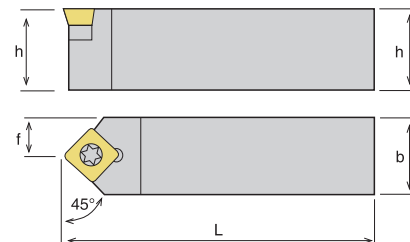
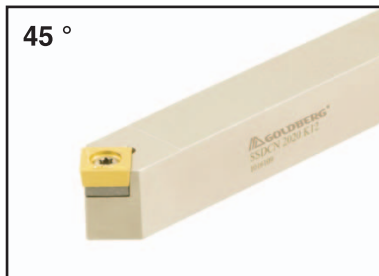

Bezeichnung Designation	Abmessungen (mm) Dimensions (mm)				Wendeplatte Insert	Ersatzteile Spare parts			
	h	b	L	f		Spannschraube für WPL Clamping screw for insert	Unterlage Shim	Schraube für Unterlage Screw for shim	Torx Schlüssel Torx key
SSDCN 1212 F 09	12	12	80	6			-	-	
1616 H 09	16	16	100	8			001021	004006	
2020 K 09	20	20	125	10					
1616 H 12	16	16	100	8			001022	004007	
2020 K 12	20	20	125	10					
2525 M 12	25	25	150	12.5					

Bestellbeispiel/Ordering example: 1 Stk/pcs. SSDCN 1212 F09

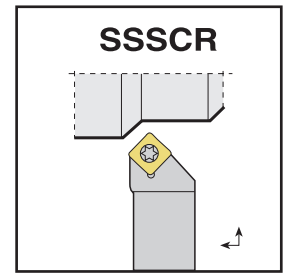
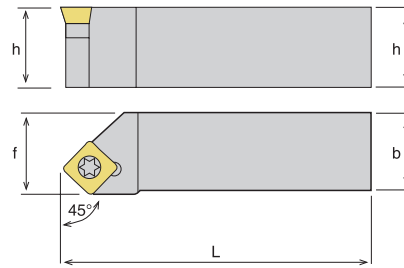

Bezeichnung Designation	Abmessungen (mm) Dimensions (mm)				Wendeplatte Insert	Ersatzteile Spare parts			
	h	b	L	f		Spannschraube für WPL Clamping screw for insert	Unterlage Shim	Schraube für Unterlage Screw for shim	Torx Schlüssel Torx key
SSSCR/L 1212 F 09	12	12	80	16			-	-	
1616 H 09	16	16	100	20		011042	001021	004006	
2020 K 09	20	20	125	25		011042	001021	004006	
1616 H 12	16	16	100	20			001022	004007	
2020 K 12	20	20	125	25		011037	001022	004007	
2525 M12	25	25	150	32		011037	001022	004007	

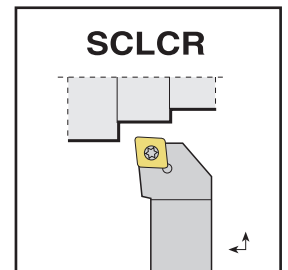
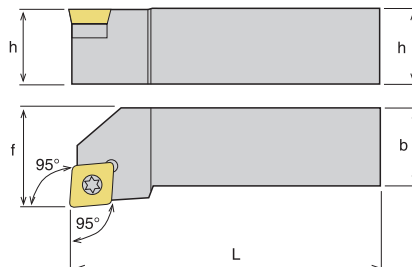
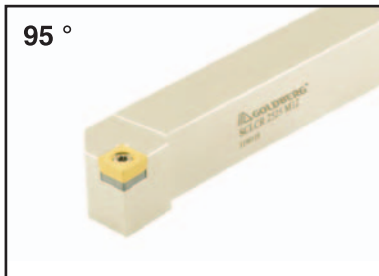

Bezeichnung Designation	Abmessungen (mm) Dimensions (mm)				Wendeplatte Insert	Ersatzteile Spare parts			
	h	b	L	f		Spannschraube für WPL Clamping screw for insert	Unterlage (UL) Shim	Schraube für Unterlage Screw for shim	Torx Schlüssel Torx key
SCLCR/L 0808 E 06	08	08	70	10			-	-	
1010 E 06	10	10	70	12		011007	-	-	
1212 F 09	12	12	80	16		011014	-	-	
1616 H 09	16	16	100	20			001011	004006	
2020 K 09	20	20	125	25		011042	001011	004006	
2020 K 12	20	20	125	25		011042	001011	004006	
2525 M12	25	25	150	32			001012	004007	

Bestellbeispiel/Ordering example: 1 Stk/pcs. SCLCR 1616 H06

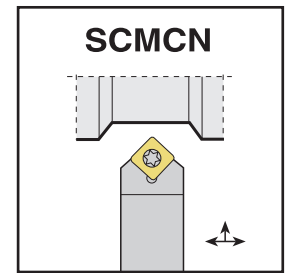
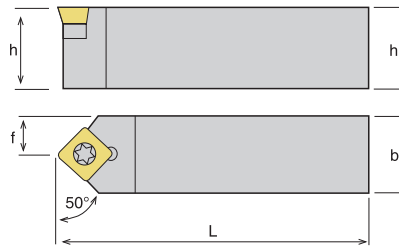

Bezeichnung Designation	Abmessungen (mm) Dimensions (mm)				Wendeplatte Insert	Ersatzteile Spare parts			
	h	b	L	f		Spannschraube für WPL Clamping screw for insert	Unterlage Shim	Schraube für Unterlage Screw for shim	Torx Schlüssel Torx key
SCMCN 0808 E 06	08	08	70	04		011007	-	-	018003
1010 E 06	10	10	70	05		011014	-	-	018005
1212 F 09	12	12	80	06		011042	001011	004006	018005
1616 H 09	16	16	100	08		011037	001012	004007	018006
2020 K 12	20	20	125	10		011037	001012	004007	018006
2525 M12	25	25	150	12,5					

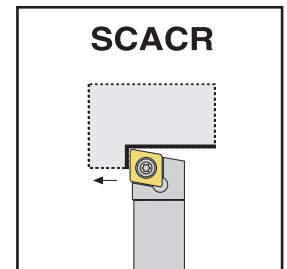
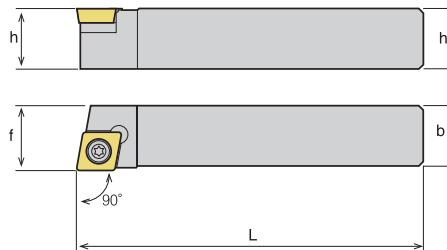

Bezeichnung Designation	Abmessungen (mm) Dimensions (mm)				Wendeplatte Insert	Ersatzteile Spare parts			
	h	b	L	f		Spannschraube für WPL Clamping screw for insert	Unterlage Shim	Schraube für Unterlage Screw for shim	Torx Schlüssel Torx key
SCACR/L 0808 E 06	08	08	70	10		011007	-	-	018003
1010 E 06	10	10	70	12		011014	-	-	018005
1212 F 09	12	12	80	16		011042	001011	004006	018005
1616 H 09	16	16	100	20		011037	001012	004007	018006
2020 K 09	20	20	125	25		011037	001012	004007	018006
2020 K 12	20	20	125	25					
2525 M12	25	25	150	32					

Bestellbeispiel/Ordering example: 1 Stk/pcs. SCACR 0808 E06

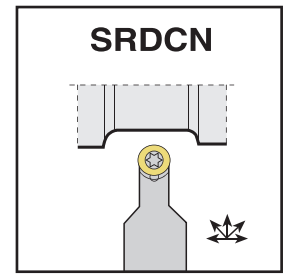
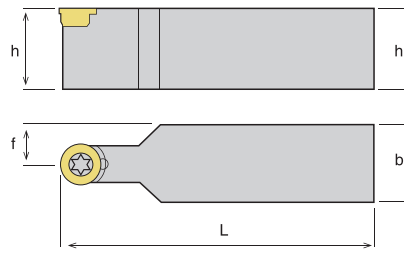
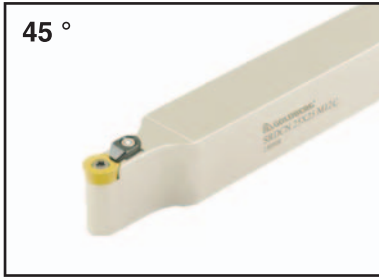

Bezeichnung Designation	Abmessungen (mm) Dimensions (mm)				Wendeplatte Insert	Ersatzteile Spare parts						
	h	b	L	f		Spannschraube Clamping screw	Unterlage (UL) Shim	Schraube für UL Screw for shim	Spannpratze Wedge clamp	Spannschraube Clamping screw	Torx Schlüssel Torx key	
SRDCN 1616 H 06	16	16	100	8		011007	-	-	-	-	018003	
2020 K 06	20	20	125	10								RC.T 06 02..
2525 M06	25	25	150	12.5								
1616 H 08C	16	16	100	8		011043	-	-	-	018005		
2020 K 08C	20	20	125	10							RC.T 08 03..	
2525 M08C	25	25	150	12.5								
1616 H 10C	16	16	100	8		011014	-	-	002022	011014	018005	
2020 K 10C	20	20	125	10					RC.T 10 T3..			
2525 M10C	25	25	150	12.5								
3232 P 10C	32	32	170	16								
2020 K 12C	20	20	125	10		011014	-	-	002014	011032	018006	
2525 M12C	25	25	150	12.5					RC.T 12 04..			
3232 P 12C	32	32	170	16								
3232 P 16C	32	32	170	16	RC.T 16 05..	011040	-	-	-	018006		

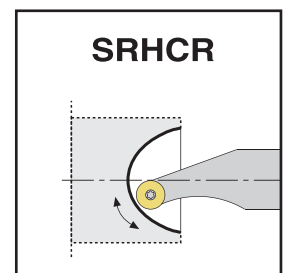
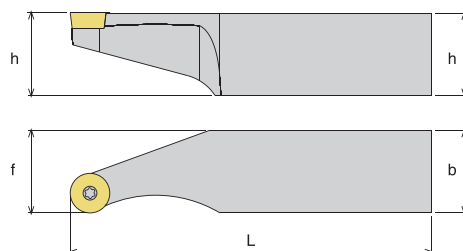

Bezeichnung Designation	Abmessungen (mm) Dimensions (mm)				Wendeplatte Insert	Ersatzteile Spare parts				
	h	b	L	f		Spannschraube Clamping screw	Unterlage (UL) Shim	Schraube für UL Screw for shim	Torx Schlüssel Torx key	
SRHCR/L 2525 K10	25	25	125	25	RC.T 10 T3..	011014	-	-	-	018005
2525 K12	25	25	125	25	RC.T 12 04..					
2525 K16	25	25	125	25	RC.T 16 06..	011040	-	-	-	018006

Bestellbeispiel/Ordering example: 1 Stk./pcs. SRHCR 2525 K10

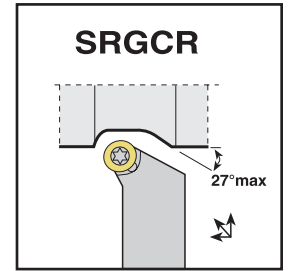
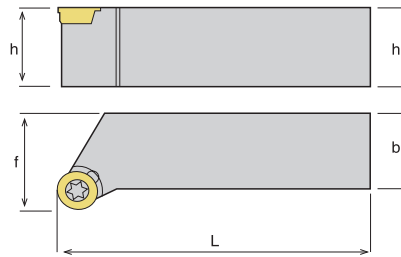



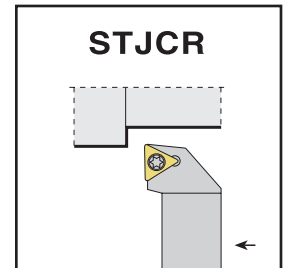
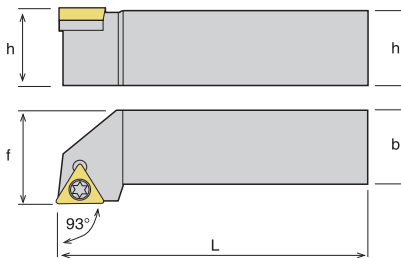

Bezeichnung Designation	Abmessungen (mm) Dimensions (mm)				Wendeplatte Insert	Ersatzteile Spare parts					
	h	b	L	f		Spannschraube Clamping screw	Unterlage (UL) Shim	Schraube für UL Screw for shim	Spannpratze Wedge clamp	Spannschraube Clamping screw	Torx Schlüssel Torx key
SRGCR/L1616 H 06	16	16	100	20			-	-	-	-	018003
2020 K 06	20	20	125	25							
1616 H 08C	16	16	100	20			-	-	002022	011014	018005
2020 K 08C	20	20	125	25							
2525 M08C	25	25	150	32							
1616 H 10C	16	16	100	20			-	-	002014	011032	018005
2020 K 10C	20	20	125	25							
2525 M10C	25	25	150	32							
3232 P 10C	32	32	170	40							
2020 K 12C	20	20	125	25			-	-	002014	011032	018005
2525 M12C	25	25	150	32							
3232 P 12C	32	32	170	40							



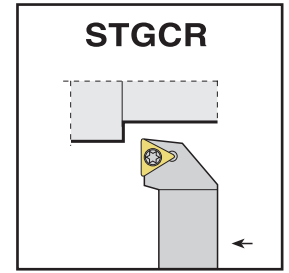
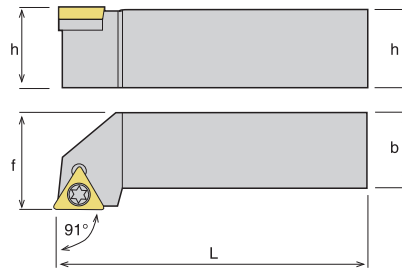
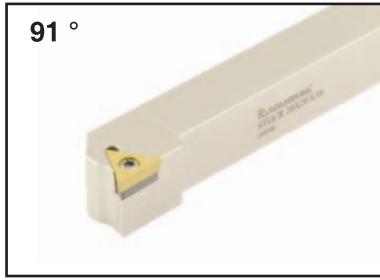

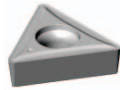

Bezeichnung Designation	Abmessungen (mm) Dimensions (mm)				Wendeplatte Insert	Ersatzteile Spare parts			
	h	b	L	f		Spannschraube Clamping screw	Unterlage (UL) Shim	Schraube für UL Screw for shim	Torx Schlüssel Torx key
STJCR/L 0808 E 09	08	08	70	10			-	-	018002
1010 E 09	10	10	70	12					
1212 F 11	12	12	80	16			-	-	018003
1616 H 11	16	16	100	20					
1616 H 16	16	16	100	20					
2020 K 16	20	20	125	25			001001	004006	018005
2525 M16	25	25	150	32					
3232 P 16	32	32	170	40					

Bestellbeispiel/Ordering example: 1 Stk./pcs. STJCR 0808 E09

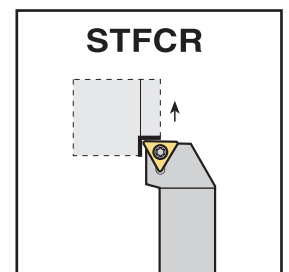
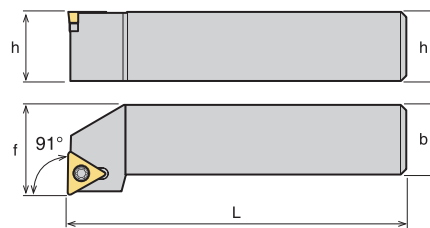

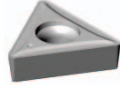



Bezeichnung Designation	Abmessungen (mm) Dimensions (mm)				Wendeplatte Insert	Ersatzteile Spare parts			
	h	b	L	f		Spanschraube Clamping screw	Unterlage (UL) Shim	Schraube für UL Screw for shim	Torx Schlüssel Torx key
STGCR/L 0808 E 09	08	08	70	10					
1010 E 09	10	10	70	12					
1212 F 11	12	12	80	16					
1616 H 11	16	16	100	20	TCM. 11 02..	011007	-	-	018003
1616 H 16	16	16	100	20	TCM. 16 T3..	011042	001001	004006	018005
2020 K 16	20	20	125	25					
2525 M16	25	25	150	32					
3232 P 16	32	32	170	40					

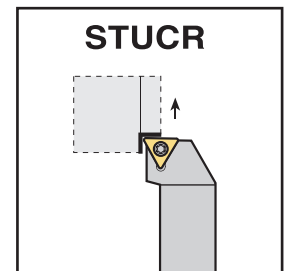
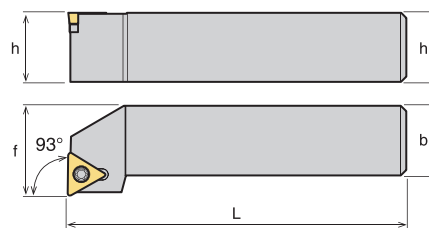

Bezeichnung Designation	Abmessungen (mm) Dimensions (mm)				Wendeplatte Insert	Ersatzteile Spare parts			
	h	b	L	f		Spanschraube Clamping screw	Unterlage (UL) Shim	Schraube für UL Screw for shim	Torx Schlüssel Torx key
STFGR/L 0808 E 09	08	08	70	10					
1010 E 09	10	10	70	12					
1212 F 11	12	12	80	16					
1616 H 11	16	16	100	20	TCM. 11 02..	011007	-	-	018003
1616 H 16	16	16	100	20	TCM. 16 T3..	011042	001001	004006	018005
2020 K 16	20	20	125	25					
2525 M16	25	25	150	32					
3232 P 16	32	32	170	40					

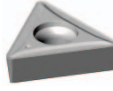
Bestellbeispiel/Ordering example: 1 Stk/pcs. STFGR 0808 E09



Bezeichnung Designation	Abmessungen (mm) Dimensions (mm)				Wendeplatte Insert 	Ersatzteile Spare parts			
	h	b	L	f		Spannschraube Clamping screw 	Unterlage (UL) Shim 	Schraube für UL Screw for shim 	Torx Schlüssel Torx key 
STUCR/L 0808 E 09	08	08	70	10	TCM. 09 02..	011004	-	-	018002
1010 E 09	10	10	70	12					
1212 F 11	12	12	80	16	TCM. 11 02..	011007	-	-	018003
1616 H 11	16	16	100	20					
1616 H 16	16	16	100	20	TCM. 16 T3..	011042	001001	004006	018005
2020 K 16	20	20	125	25					
2525 M16	25	25	150	32					
3232 P 16	32	32	170	40					

Bestellbeispiel/Ordering example: 1 Stk/pcs. STUCR 0808 E09

Drehhalter für Langdrehautomaten / *Toolholders for automatic lathes*



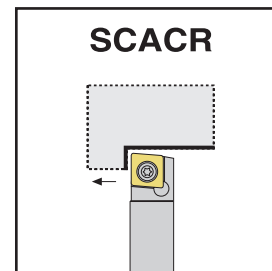
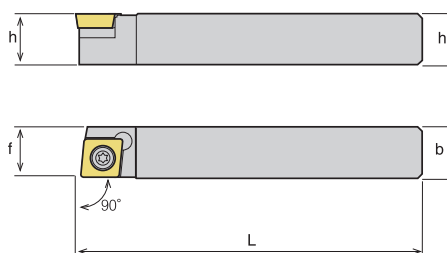

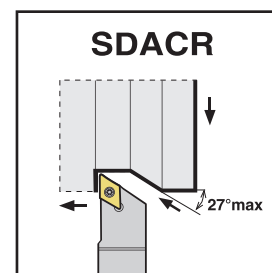
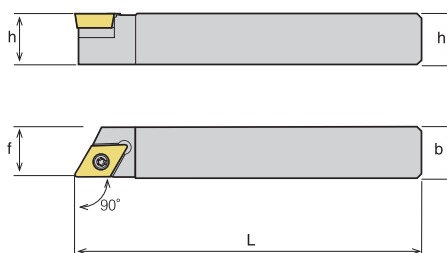

Bezeichnung Designation	Abmessungen (mm) Dimensions (mm)				Wendeplatte Insert	Ersatzteile Spare parts	
	d	h	L	f		Spannschraube Clamping screw	Torx Schlüssel Torx key
SCACR/L 1010 K06-S	10	10	125	10		011007	018003
SCACR/L 1212 K09-S	12	12	125	12		011014	018005
SCACR/L 1616 K09-S	16	16	125	16	CC.T. 09T3..	011042	018006
SCACR/L 2020 K09-S	20	20	125	20		011037	





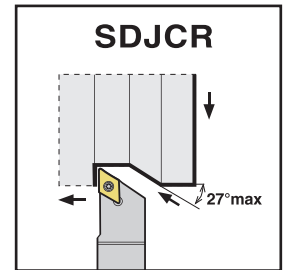
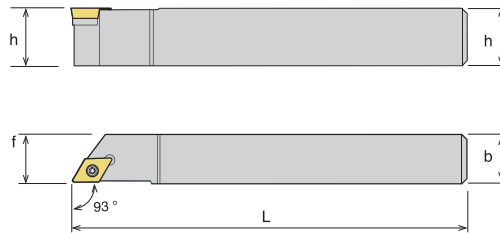
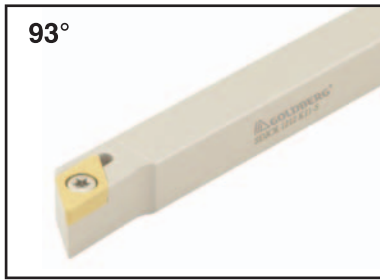

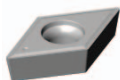
Bezeichnung Designation	Abmessungen (mm) Dimensions (mm)				Wendeplatte Insert	Ersatzteile Spare parts	
	d	h	L	f		Spannschraube Clamping screw	Torx Schlüssel Torx key
SDACR/L 1010 K07-S	10	10	125	10		011007	018003
SDACR/L 1212 K07-S	12	12	125	12			
SDACR/L 1616 K07-S	16	16	125	16			
SDACR/L 1212 K11-S	12	12	125	12	DC.T. 11T3..	011042	018005
SDACR/L 1616 K11-S	16	16	125	16			
SDACR/L 2020 K11-S	20	20	125	20			

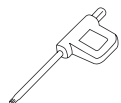
Bestellbeispiel/Ordering example: 1 Stk/pcs. SDACR 1010 K07 S

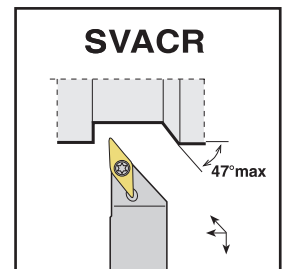
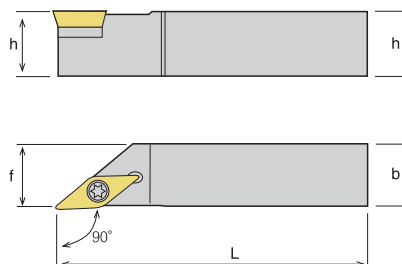

Bezeichnung Designation	Abmessungen (mm) Dimensions (mm)				Wendeplatte Insert	Ersatzteile Spare parts	
	d	h	L	f		Spannschraube Clamping screw	Torx Schlüssel Torx key
SDJCR/L 1212 K11-S	12	12	125	12			
SDJCR/L 1616 K11-S	16	16	125	16			



Bezeichnung Designation	Abmessungen (mm) Dimensions (mm)				Wendeplatte Insert	Ersatzteile Spare parts				
	d	h	L	f		Spannschraube Clamping screw	Torx Schlüssel Torx key			
SVACR/L 1212 K11-S	12	12	125	12						
SVACR/L 1616 K11-S	16	16	125	16				VC.T 1103..	011007	018003
SVACR/L 2020 K11-S	20	20	125	20						

Bestellbeispiel/Ordering example: 1 Stk/pcs. SVACR 1212 K11 S

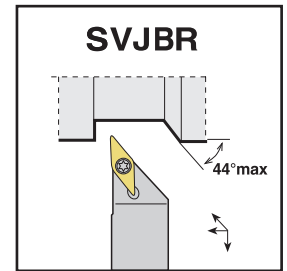
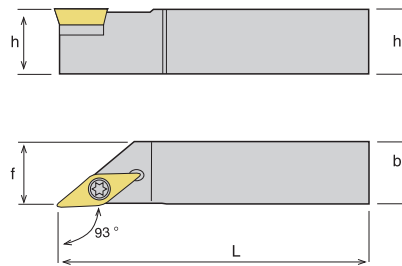

Bezeichnung Designation	Abmessungen (mm) Dimensions (mm)				Wendeplatte Insert	Ersatzteile Spare parts	
	d	h	L	f		Spannschraube Clamping screw	Torx Schlüssel Torx key
SVJBR/L 1616 K11-S	16	16	125	16	 VBM. 1103..	 011007	 018003

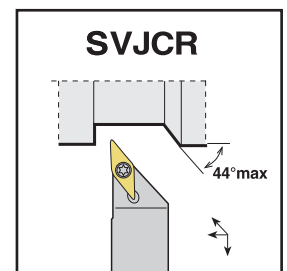
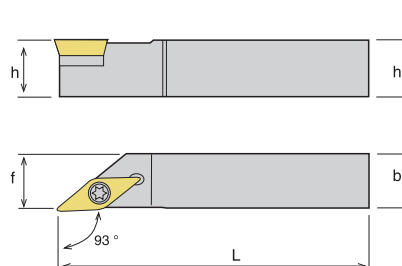

Bezeichnung Designation	Abmessungen (mm) Dimensions (mm)				Wendeplatte Insert	Ersatzteile Spare parts	
	d	h	L	f		Spannschraube Clamping screw	Torx Schlüssel Torx key
SVJCR/L 1212 K11-S	12	12	125	12	 VC.T 1103..	 011007	 018003

Bestellbeispiel/Ordering example: 1 Stk/pcs. SVJCR 1212 K11 S

P-System Außendrehhalter / *P-System external toolholders*



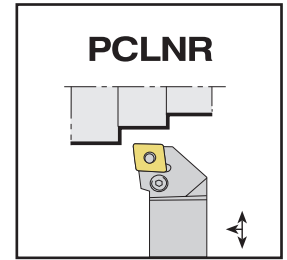
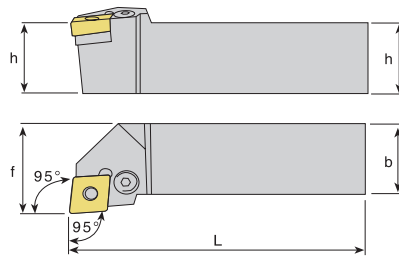
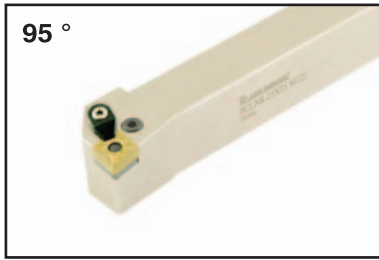

Bezeichnung Designation	Abmessungen (mm) Dimensions (mm)				Wendeplatte Insert	Ersatzteile Spare parts						
	h	b	L	f		Hebel (H) Lever	Schraube für H Screw for lever	Unterlage (UL) Shim	Druckfeder für UL Pressure spring	Spannpratze Wedge clamp	Spannschraube Clamping screw	Winkelschlüssel Allen key
PCLNR/L 1616 H 09	16	16	100	20	CNM. 09 03..					-	-	017002
2020 K 09	20	20	125	25								
2525 M 09	25	25	150	32								
1616 H 12C	16	16	100	20	CNM. 12 04..					002014	011032	017003
2020 K 12C	20	20	125	25								
2525 M 12C	25	25	150	32								
3232 P 12C	32	32	170	40	CNM. 16 06..					002018	003010	017004
2525 M 16C	25	25	150	32								
3232 P 16C	32	32	170	40								
2525 M 19C	25	25	150	32	CNM. 19 06..					002013	003015	017005
3232 P 19C	32	32	170	40								
4040 S 19C	40	40	250	50								
4040 S 25C	40	40	250	50	CNM. 25 09..					002013	003015	017005
5050 S 25C	50	50	250	60								

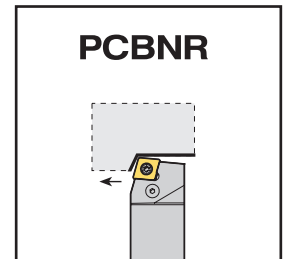
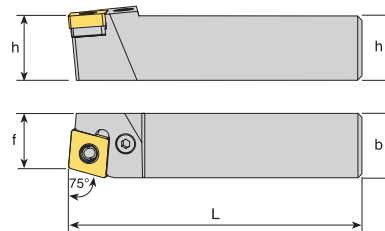

Bezeichnung Designation	Abmessungen (mm) Dimensions (mm)				Wendeplatte Insert	Ersatzteile Spare parts						
	h	b	L	f		Hebel (H) Lever	Schraube für H Screw for lever	Unterlage (UL) Shim	Druckfeder für UL Pressure spring	Spannpratze Wedge clamp	Spannschraube Clamping screw	Winkelschlüssel Allen key
PCBNR/L 2020 K 12C	20	20	125	25	CNM. 12 04..					002014	011032	017003
2525 M 12C	25	25	150	32								
3232 P 12C	32	32	170	40								
2525 M 16C	25	25	150	32	CNM. 16 06..					002018	003010	017004
3232 P 16C	32	32	170	40								
3232 P 19C	32	32	170	40								
4040 S 19C	40	40	250	50	CNM. 19 06..					002013	003015	017005
4040 S 25C	40	40	250	50								
5050 S 25C	50	50	250	60								

Bestellbeispiel/Ordering example: 1 Stk/pcs. PCBNR 2020 K12C

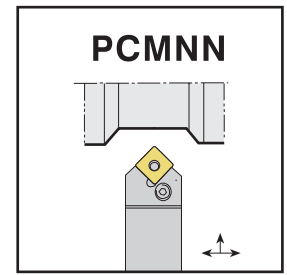
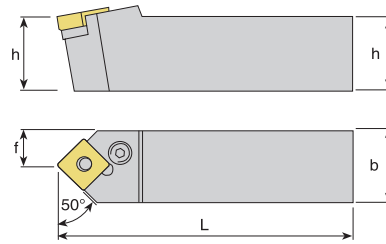
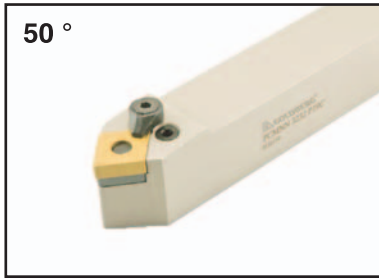

Bezeichnung Designation	Abmessungen (mm) Dimensions (mm)				Wendeplatte Insert	Ersatzteile Spare parts														
	h	b	L	f		Hebel (H) Lever	Schraube für H Screw for lever	Unterlage (UL) Shim	Druckfeder für UL Pressure spring	Spannpratze Wedge clamp	Spannschraube Clamping screw	Winkelschlüssel Allen key								
PCMNN 2020 K 12C	20	20	125	10																
2525 M 12C	25	25	150	12.5									CNM. 12 04..	008002	009003	001023	010002	002014	011032	017003
3232 P 12C	32	32	170	16																
2525 M 16C	25	25	150	12.5																
3232 P 16C	32	32	170	16									CNM. 16 06..	008004	009004	001024	010003			
3232 P 19C	32	32	170	16														002018	003010	017004
4040 S 19C	40	40	250	20																
5050 S 19C	50	50	250	25									CNM. 19 06..	008005	009005	001025	010004			

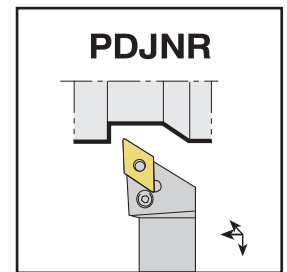
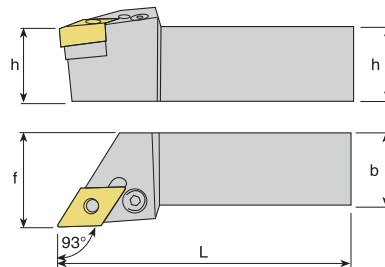

Bezeichnung Designation	Abmessungen (mm) Dimensions (mm)				Wendeplatte Insert	Ersatzteile Spare parts														
	h	b	L	f		Hebel (H) Lever	Schraube für H Screw for lever	Unterlage (UL) Shim	Druckfeder für UL Pressure spring	Spannpratze Wedge clamp	Spannschraube Clamping screw	Winkelschlüssel Allen key								
PDJNR/L 1616 H 11	16	16	100	20																
2020 K 11	20	20	125	25									DNM. 11 04..	008001	009002	001029	010001	-	-	017002
2525 M 11	25	25	150	32																
2020 K 15C	20	20	125	25																
2525 M 15C	25	25	150	32									DNM. 15 06..	008003	009003	001030	010002	002014	011032	017003
3232 P 15C	32	32	170	40																

Bestellbeispiel/Ordering Example: 1 Stk/pcs. PDJNR 1616 H11

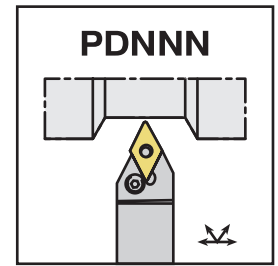
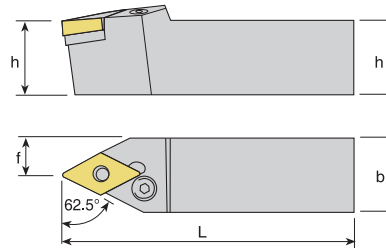
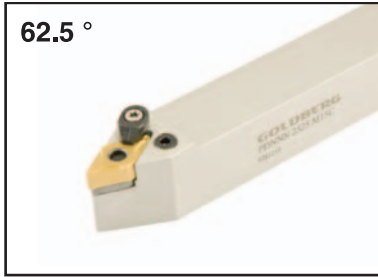

Bezeichnung Designation	Abmessungen (mm) Dimensions (mm)				Wendeplatte Insert	Ersatzteile Spare parts														
	h	b	L	f		Hebel (H) Lever	Schraube für H Screw for lever	Unterlage (UL) Shim	Druckfeder für UL Pressure spring	Spannpratze Wedge clamp	Spannschraube Clamping screw	Winkelschlüssel Allen key								
PDNN 1616 H 11	16	16	100	8																
2020 K 11	20	20	125	10									DNM. 11 04..	008001	009002	001029	010001	-	-	017002
2525 M 11	25	25	150	12.5																
2020 K 15C	20	20	125	10																
2525 M 15C	25	25	150	12.5									DNM. 15 06..	008003	009003	001030	010002	002014	011032	017003
3232 P 15C	32	32	170	16																

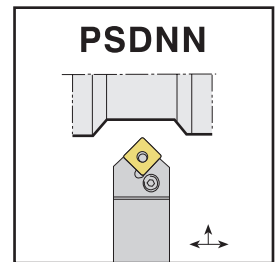
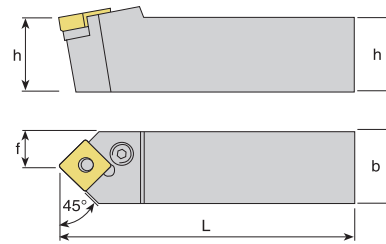

Bezeichnung Designation	Abmessungen (mm) Dimensions (mm)				Wendeplatte Insert	Ersatzteile Spare parts														
	h	b	L	f		Hebel (H) Lever	Schraube für H Screw for lever	Unterlage (UL) Shim	Druckfeder für UL Pressure spring	Spannpratze Wedge clamp	Spannschraube Clamping screw	Winkelschlüssel Allen key								
PSDNN 1616 H 09	16	16	100	8																
2020 K 12C	20	20	125	10									SNM. 09 03..	008009	009009	001035	010007	-	-	017002
2525 M12C	25	25	150	12.5									SNM. 12 04..	008002	009003	001023	010002	002014	011032	017003
3232 P 12C	32	32	170	16																
2020 K 15C	20	20	125	10									SNM. 15 06..	008004	009004	001024	010003			
2525 M15C	25	25	150	12.5																
3232 P 19C	32	32	170	16																
4040 S 19C	40	40	250	20									SNM. 19 06..	008005	009005	001025	010004	002018	003010	017004
5050 S 19C	50	50	250	25																
4040 S 25C	40	40	250	20																
5050 S 25C	50	50	250	25									SNM. 25 07..	008006	009006	001026	010005	002013	003015	017005

Bestellbeispiel/Ordering example: 1 Stk/pcs. PSDNN 1616 H09

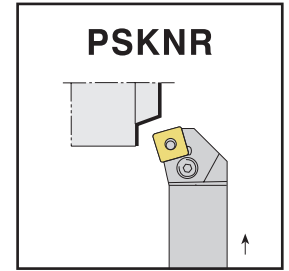
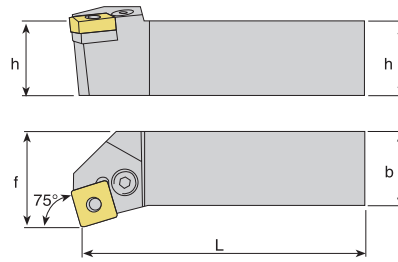
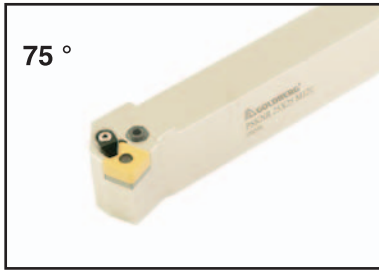

Bezeichnung Designation	Abmessungen (mm) Dimensions (mm)				Wendeplatte Insert	Ersatzteile Spare parts						
	h	b	L	f		Hebel (H) Lever	Schraube für H Screw for lever	Unterlage (UL) Shim	Druckfeder für UL Pressure spring	Spannpratze Wedge clamp	Spannschraube Clamping screw	Winkelschlüssel Allen key
PSKNR/L 2020 K 09	20	20	125	25	SNM. 09 03..	008009	009009	001035	010007	-	-	017002
2020 K 12C	20	20	125	25	SNM. 12 04..	008002	009003	001023	010002	002014	011032	017003
2525 M 12C	25	25	150	32								
3232 P 12C	32	32	170	40								
2525 M 15C	25	25	150	32	SNM. 15 06..	008004	009004	001024	010003	002018	003010	017004
3232 P 15C	32	32	170	40								
3232 P 19C	32	32	170	40	SNM. 19 06..	008005	009005	001025	010004	002013	003015	017005
4040 S 19C	40	40	250	50								
4040 S 25C	40	40	250	50	SNM. 25 07..	008006	009006	001026	010005	002013	003015	017005
5050 S 25C	50	50	250	60								

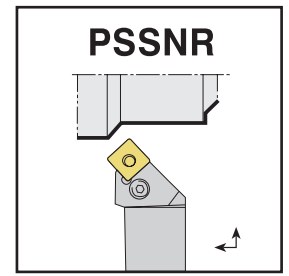
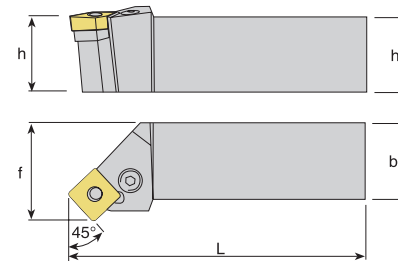

Bezeichnung Designation	Abmessungen (mm) Dimensions (mm)				Wendeplatte Insert	Ersatzteile Spare parts						
	h	b	L	f		Hebel (H) Lever	Schraube für H Screw for lever	Unterlage (UL) Shim	Druckfeder für UL Pressure spring	Spannpratze Wedge clamp	Spannschraube Clamping screw	Winkelschlüssel Allen key
PSSNR/L 1616 H 09	16	16	100	20	SNM. 09 03..	008009	009009	001035	010007	-	-	017002
2020 K 09	20	20	125	25								
2020 K 12C	20	20	125	25	SNM. 12 04..	008002	009003	001023	010002	002014	011032	017003
2525 M 12C	25	25	150	32								
3232 P 12C	32	32	170	40								
3232 P 15C	32	32	170	40	SNM. 15 06..	008004	009004	001024	010003	002018	003010	017004
3232 P 19C	32	32	170	40								
4040 S 19C	40	40	250	50	SNM. 19 06..	008005	009005	001025	010004	002013	003015	017005
4040 S 25C	40	40	250	50								

Bestellbeispiel/Ordering example: 1 Stk/pcs. PSSNR 1616 H09

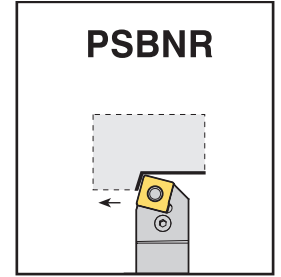
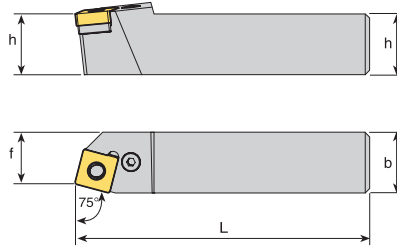
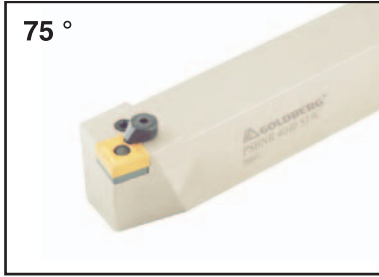

Bezeichnung Designation	Abmessungen (mm) Dimensions (mm)				Wendeplatte Insert	Ersatzteile Spare parts						
	h	b	L	f		Hebel (H) Lever	Schraube für H Screw for lever	Unterlage (UL) Shim	Druckfeder für UL Pressure spring	Spannpratze Wedge clamp	Spannschraube Clamping screw	Winkelschlüssel Allen key
PSBNR/L 1616 H 09	16	16	100	20	SNM. 09 03..					-	-	017002
2020 K 09	20	20	125	25						-	-	
2020 K 12C	20	20	125	25	SNM. 12 04..							017003
2525 M 12C	25	25	150	32								
3232 P 12C	32	32	170	40								
2525 M 15C	25	25	150	32	SNM. 15 06..					-	-	017004
3232 P 19C	32	32	170	40								
4040 S 19C	40	40	250	50	SNM. 19 06..							017004
4040 S 25C	40	40	250	50								
5050 S 25C	50	50	250	63	SNM. 25 07..							017005

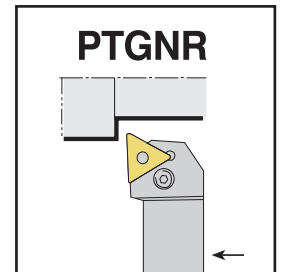
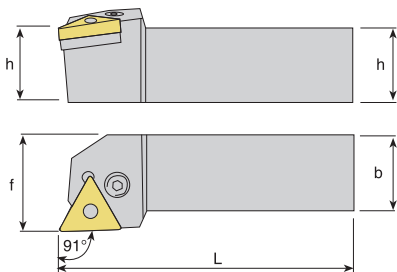

Bezeichnung Designation	Abmessungen (mm) Dimensions (mm)				Wendeplatte Insert	Ersatzteile Spare parts						
	h	b	L	f		Hebel (H) Lever	Schraube für H Screw for lever	Unterlage (UL) Shim	Druckfeder für UL Pressure spring	Spannpratze Wedge clamp	Spannschraube Clamping screw	Winkelschlüssel Allen key
PTGNR/L 1010 E 11	10	10	70	12	TNM. 11 03..					-	-	017002
1212 F 11	12	12	80	16						-	-	
1616 H 11	16	16	100	20						-	-	
1616 H 16	16	16	100	20	TNM. 16 04..					-	-	017003
2020 K 16	20	20	125	25								
2525 M 16	25	25	150	32								
3232 P 16	32	32	170	40								
2525 M 22C	25	25	150	32	TNM. 22 04..							017003
3232 P 22C	32	32	170	40								
4040 S 27	40	40	250	50	TNM. 27 06..							017004

Bestellbeispiel/Ordering example: 1 Stk/pcs. PTGNR 1010 E11

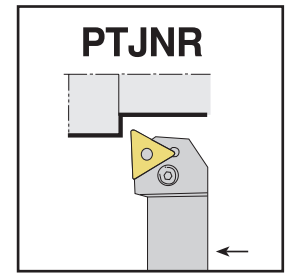
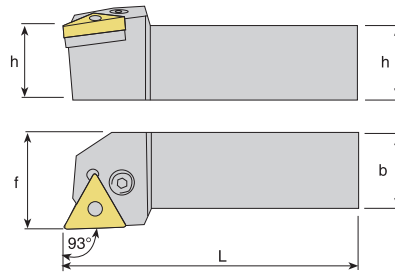
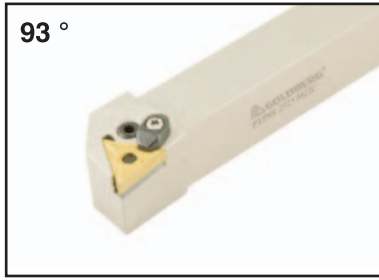

Bezeichnung Designation	Abmessungen (mm) Dimensions (mm)				Wendeplatte Insert	Ersatzteile Spare parts						
	h	b	L	f		Hebel (H) Lever	Schraube für H Screw for lever	Unterlage (UL) Shim	Druckfeder für UL Pressure spring	Spannpratze Wedge clamp	Spannschraube Clamping screw	Winkelschlüssel Allen key
PTJNR/L 1010 E 11	10	10	70	12	TNM. 11 03..	008010	009010	-	-	-	-	017002
1212 F 11	12	12	80	16								
1616 H 11	16	16	100	20								
1616 H 16	16	16	100	20	TNM. 16 04..	008001	009002	001003	010001	-	-	017002
2020 K 16	20	20	125	25								
2525 M16	25	25	150	32								
3232 P 16	32	32	170	40								
2525 M22C	25	25	150	32	TNM. 22 04..	008002	009003	001004	010002	002014	011032	017003
3232 P 22C	32	32	170	40								
4040 S 27	40	40	250	50	TNM. 27 06..	008011	009011	001036	010008	-	-	017004

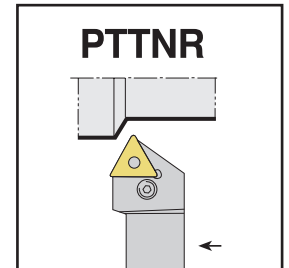
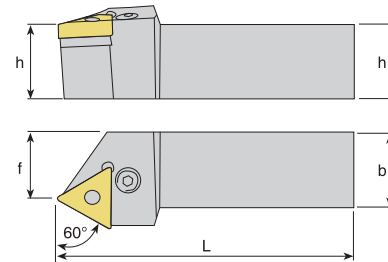

Bezeichnung Designation	Abmessungen (mm) Dimensions (mm)				Wendeplatte Insert	Ersatzteile Spare parts						
	h	b	L	f		Hebel (H) Lever	Schraube für H Screw for lever	Unterlage (UL) Shim	Druckfeder für UL Pressure spring	Spannpratze Wedge clamp	Spannschraube Clamping screw	Winkelschlüssel Allen key
PTTNR/L1616 H 16	16	16	100	13	TNM. 16 04..	008001	009002	001003	010001	-	-	017002
2020 K 16	20	20	125	17								
2525 M16	25	25	150	21,5								
3232 P 16	32	32	170	31								
2525 M22C	25	25	150	20,5	TNM. 22 04..	008002	009003	001004	010002	002014	011032	017003
3232 P 22C	32	32	170	29								

Bestellbeispiel/Ordering example: 1 Stk/pcs. PTTNR 1616 H16

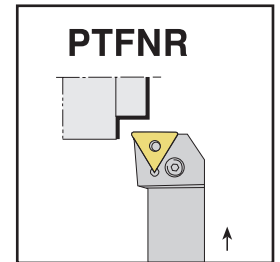
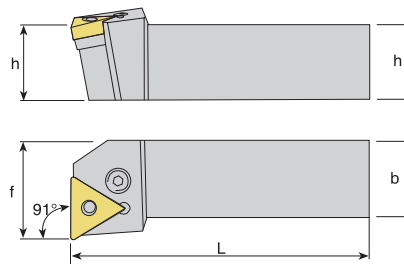
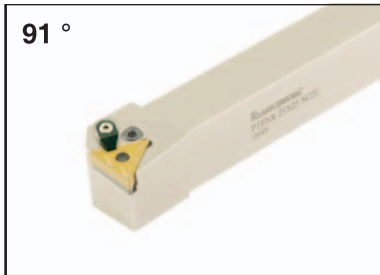

Bezeichnung Designation	Abmessungen (mm) Dimensions (mm)				Wendeplatte Insert	Ersatzteile Spare parts														
	h	b	L	f		Hebel (H) Lever	Schraube für H Screw for lever	Unterlage (UL) Shim	Druckfeder für UL Pressure spring	Spannpratze Wedge clamp	Spannschraube Clamping screw	Winkelschlüssel Allen key								
PTFNR/L 1616 H 16	16	16	100	20																
2020 K 16	20	20	125	25									TNM. 16 04..	008001	009002	001003	010001	-	-	017002
2525 M 16	25	25	150	32																
3232 P 16	32	32	170	40																
2525 M 22C	25	25	150	32																
3232 P 22C	32	32	170	40									TNM. 22 04..	008002	009003	001004	010002	002014	011032	017003
4040 S 27	40	40	250	50																

Bestellbeispiel/Ordering example: 1 Stk/pcs. PWFNR 1616 H06

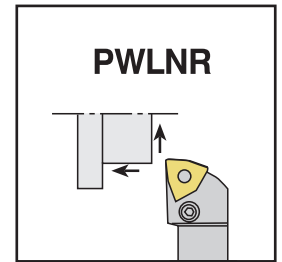
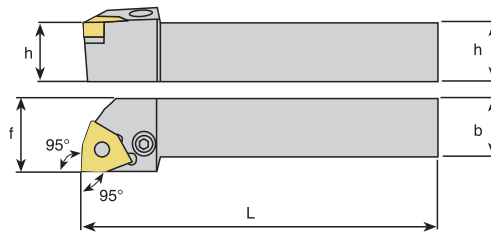
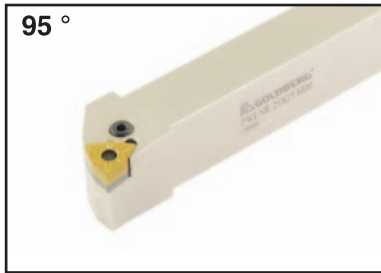

Bezeichnung Designation	Abmessungen (mm) Dimensions (mm)				Wendeplatte Insert	Ersatzteile Spare parts						
	h	b	L	f		Hebel (H) Lever	Schraube für H Screw for lever	Unterlage (UL) Shim	Druckfeder für UL Pressure spring	Spannpratze Wedge clamp	Spannschraube Clamping screw	Winkelschlüssel Allen key
PWLNR/L 1616 H 06	16	16	100	20	WNM. 06 04.. 							
2020 K 06	20	20	125	25								
2525 M06	25	25	150	32								
3232 P 06	32	32	170	40								
1616 H 08	16	16	100	20	WNM. 08 04.. 							
2020 K 08C	20	20	125	25								
2525 M08C	25	25	150	32								
3232 P 08C	32	32	170	40								

Bestellbeispiel/Ordering example: 1 Stk/pcs. PWLNR 1616 H06



1 Grundform der Wendeschneidplatte / Basic shape of indexable insert

A: Vollstahlausführung mit innere Kühlmittelzufuhr / Solid steel design with internal coolant supply
 E: Hartmetallschaft mit Kopf aus Stahl und innere Kühlmittelzufuhr / Carbide shank with steel head and supply internal coolant
 C: Hartmetallschaft mit Kopf aus Stahl ohne innere Kühlmittelzufuhr / Carbide shank with steel head and without internal coolant supply
 S: Vollstahlausführung ohne innere Kühlmittelzufuhr / Solid steel design without internal coolant supply

2 Bohrstangendurchmesser (mm) / Boring bar diameter (mm)

3 Drehhalterlänge (mm) / Turning toolholder length (mm)

4 Art der Schneidplattenbefestigung / Type of insert mounting

C T M P S

A-32	H-100	Q-180	x-special (mm)
B-40	J-110	R-200	
C-50	K-125	S-250	
D-60	L-140	T-300	
E-70	M-150	U-350	
F-80	N-160	V-400	
G-90	P-170	W-450	

5 Grundform der Wendeschneidplatte / Basic shape of indexable insert

C	D	E
V	R	S
W	K	T

6 Anstellwinkel / Approach angle

7 Freiwinkel der Wendeschneidplatte / Indexable insert clearance angle

8 Drehhalterauführung / Turning toolholder version

9 Länge der Schneidkante (mm) / Length of cutting edge (mm)

9 Spannpratze / clamping wedge

T&C-System Innendrehhalter / *T&C-System internal toolholders*



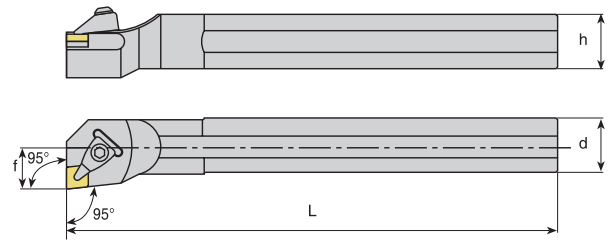
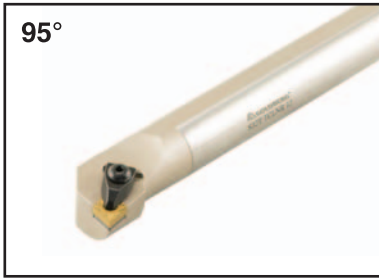

Bezeichnung Designation	Abmessungen (mm) Dimensions (mm)					Wendeplatte Insert	Ersatzteile Spare parts						
	d	h	L	f	D min		Spannpratze Wedge clamp	Spannschraube Clamp screw	Unterlage (UL) Shim	Schraube für UL Screw for shim	Druckfeder Pressure spring	Unterlegscheibe Washer	Winkelschlüssel Allen key
S25S TCLNR/L 09	25	23	250	17	≥32	CNM. 09 03..	002001	003001	001011	004004	-		
S25S TCLNR/L 12	25	23	250	17	≥32	CNM. 12 04..	002002	003002	001013	004002	006001	005001	017003
S32T TCLNR/L 12	32	30	300	22	≥40								
S40U TCLNR/L 12	40	37	350	27	≥50								
S50V TCLNR/L 12	50	47	400	35	≥63	CNM. 16 06..	002004	003005	001014	003010	-	-	017004
S32T TCLNR/L 16	32	30	300	22	≥40								
S40U TCLNR/L 16	40	37	350	27	≥50								
S50V TCLNR/L 16	50	47	400	35	≥63								

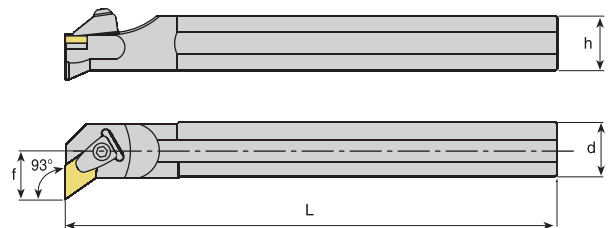

Bezeichnung Designation	Abmessungen (mm) Dimensions (mm)					Wendeplatte Insert	Ersatzteile Spare parts						
	d	h	L	f	D min		Spannpratze Wedge clamp	Spannschraube Clamp screw	Unterlage (UL) Shim	Schraube für UL Screw for shim	Druckfeder Pressure spring	Unterlegscheibe Washer	Winkelschlüssel Allen key
S25S TDUNR/L 11	25	23	250	17	≥32	DNM. 11 04..	002001	003001	001028	004004	-		
S32T TDUNR/L 11	32	30	300	22	≥40	DNM. 15 06..	002002	003002	001030	004002	006001	005001	017003
S25S TDUNR/L 15	25	23	250	17	≥32								
S32T TDUNR/L 15	32	30	300	22	≥40								
S40U TDUNR/L 15	40	37	350	27	≥50								
S50V TDUNR/L 15	50	47	400	35	≥63								

Bestellbeispiel/Ordering example: 1 Stk./pcs. S25S TDUNR 11

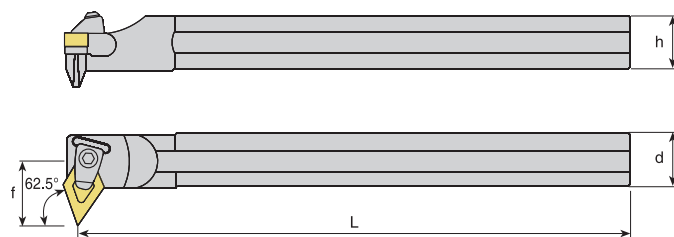

Bezeichnung Designation	Abmessungen (mm) Dimensions (mm)					Wendeplatte Insert	Ersatzteile Spare parts							
	d	h	L	f	D min		Spannpratze Wedge clamp	Spannschraube Clamping screw	Unterlage (UL) Shim	Schraube für UL Screw for shim	Druckfeder Pressure spring	Unterlegscheibe Washer	Winkelschlüssel Allen key	
S32T TD-NR/L 15	32	30	300	26	≥44									
S40U TD-NR/L 15	40	37	350	29	≥52									DNM. 15 06..
S50V TD-NR/L 15	50	47	400	35	≥67									

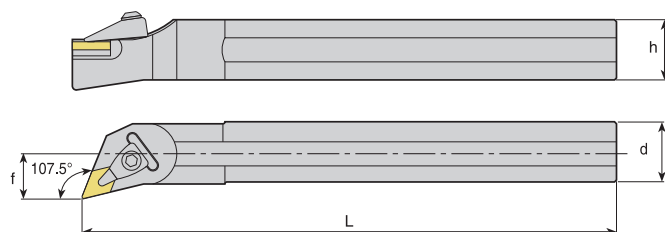

Bezeichnung Designation	Abmessungen (mm) Dimensions (mm)					Wendeplatte Insert	Ersatzteile Spare parts							
	d	h	L	f	D min		Spannpratze Wedge clamp	Spannschraube Clamping screw	Unterlage (UL) Shim	Schraube für UL Screw for shim	Druckfeder Pressure spring	Unterlegscheibe Washer	Winkelschlüssel Allen key	
S25S TDQNR/L 11	25	23	250	17	≥32									
S32T TDQNR/L 11	32	30	300	22	≥40									DNM. 11 04..
S32T TDQNR/L 15	32	30	300	22	≥40									
S40U TDQNR/L 15	40	37	350	27	≥50									DNM. 15 06..
S50V TDQNR/L 15	50	47	400	35	≥63									

Bestellbeispiel/Ordering example: 1 Stk/pcs. S25S TDQNR 11

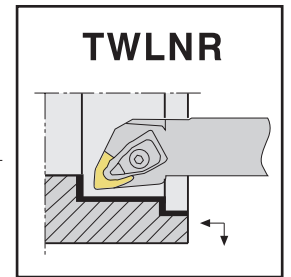
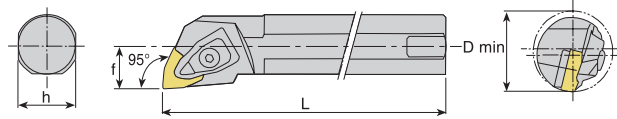

Bezeichnung Designation	Abmessungen (mm) Dimensions (mm)					Wendeplatte Insert	Ersatzteile Spare parts						
	d	h	L	f	D min		Spannpratze	Spannschraube	Unterlage (UL)	Schraube für UL	Druckfeder	Unterlegscheibe	Winkelschlüssel
							Wedge clamp	Clamping screw	Shim	Screw for shim	Pressure spring	Washer	Allen key
S25S TWLNR/L 06	25	23	250	17	≥32	WNM. 06 04..							
S32T TWLNR/L 06	32	30	300	22	≥40								
S25S TWLNR/L 08	25	23	250	17	≥32	WNM. 08 04..							
S32T TWLNR/L 08	32	30	300	22	≥40								
S40U TWLNR/L 08	40	37	350	27	≥50								
S50V TWLNR/L 08	50	47	400	35	≥63								

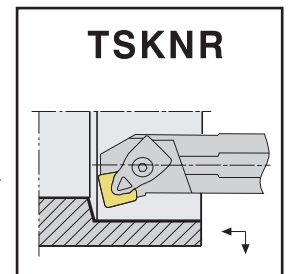
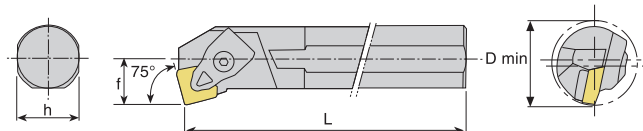

Bezeichnung Designation	Abmessungen (mm) Dimensions (mm)					Wendeplatte Insert	Ersatzteile Spare parts						
	d	h	L	f	D min		Spannpratze	Spannschraube	Unterlage (UL)	Schraube für UL	Druckfeder	Unterlegscheibe	Winkelschlüssel
							Clamp screw	clamping screw	Shim	Screw for shim	Pressure spring	Washer	Allen key
S25S TSKNR/L 12	25	23	250	17	≥32	SNM. 12 04..							
S32T TSKNR/L 12	32	30	300	22	≥40								
S40U TSKNR/L 12	40	37	350	27	≥50								

Bestellbeispiel/Ordering example: 1 Stk/pcs. S25S TSKNR 12

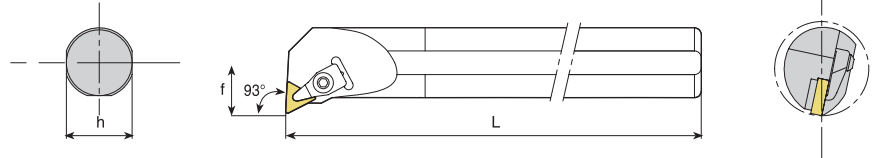
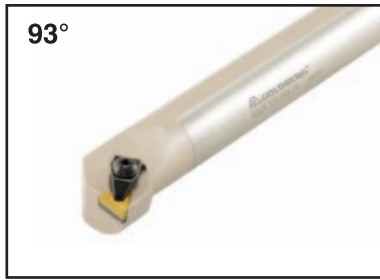

Bezeichnung Designation	Abmessungen (mm) Dimensions (mm)					Wendeplatte Insert	Ersatzteile Spare parts													
	d	h	L	f	D min		Spannpratze Wedge clamp	Spannschraube clamping screw	Unterlage (UL) Shim	Schraube für UL Screw for shim	Druckfeder Pressure spring	Unterlegscheibe Washer	Winkelschlüssel Allen key							
S25S TTUNR/L 16	25	23	250	17	≥32															
S32T TTUNR/L 16	32	30	300	22	≥40									002001	003001	001002	004003	-		
S32T TTUNR/L 22	32	30	300	22	≥40															
S40U TTUNR/L 22	40	37	350	27	≥50									002002	003002	001004	004002	006001		
S50V TTUNR/L 22	50	47	400	35	≥63															

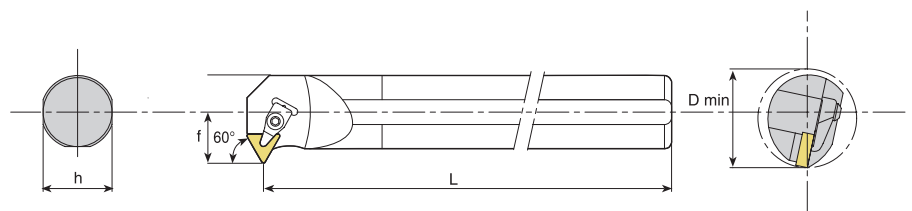

Bezeichnung Designation	Abmessungen (mm) Dimensions (mm)					Wendeplatte Insert	Ersatzteile Spare parts						
	d	h	L	f	D min		Spannpratze Wedge clamp	Spannschraube clamping screw	Unterlage (UL) Shim	Schraube für UL Screw for shim	Druckfeder Pressure spring	Unterlegscheibe Washer	Winkelschlüssel Allen key
S25S TT-NR/L 16	25	23	250	17	≥32								
S32T TT-NR/L 16	32	30	300	22	≥40								

Bestellbeispiel/Ordering example: 1 Stk/pcs. S25S TT-NR 16

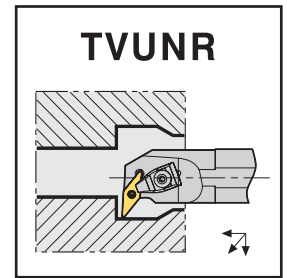
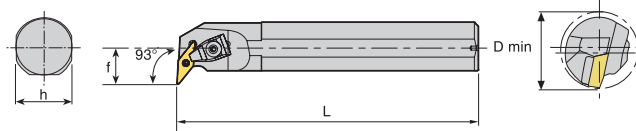

Bezeichnung Designation	Abmessungen (mm) Dimensions (mm)					Wendeplatte Insert	Ersatzteile Spare parts														
	d	h	L	f	D min		Spannpratze	Spannschraube	Unterlage (UL)	Schraube für UL	Druckfeder	Unterlegscheibe	Winkelschlüssel								
							Wedge clamp	clamping screw	Shim	Screw for shim	Pressure spring	Washer	Allen key								
S25S TVUNR/L 16	25	23	250	17	≥32																
S32T TVUNR/L 16	32	30	300	22	≥40									VNM. 16 04..	002001	003001	001032	004004	-	005001	017003
S40U TVUNR/L 16	40	37	350	27	≥50																

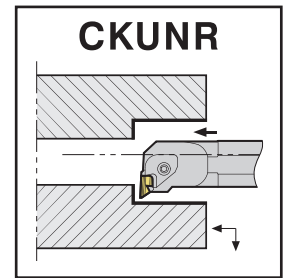
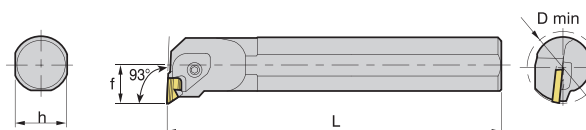

Bezeichnung Designation	Abmessungen (mm) Dimensions (mm)					Wendeplatte Insert	Ersatzteile Spare Parts														
	d	h	L	f	D min		Spannpratze	Spannschraube	Unterlage (UL)	Schraube für UL	Druckfeder	Unterlegscheibe	Winkelschlüssel								
							Wedge clamp	clamping screw	Shim	Screw for shim	Pressure spring	Washer	Allen key								
S25S CKUNR/L 16	25	23	250	19	≥34																
S32T CKUNR/L 16	32	30	300	22	≥40									KNUX 16 04..	002010-R	003006	001020	004001	006002	005001	017004
S40U CKUNR/L 16	40	37	350	27	≥50										002011-L		001019				
S50V CKUNR/L 16	50	47	400	35	≥63																

Bestellbeispiel/Ordering example: 1 Stk./pcs. S25S CKUNR 16

M-System Innendrehhalter /
M-System internal toolholders



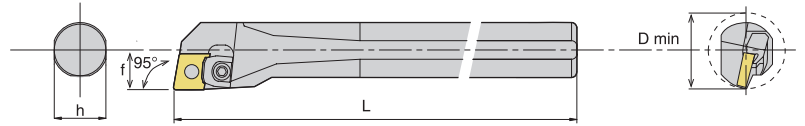

Bezeichnung Designation	Abmessungen (mm) Dimensions (mm)					Wendeplatte Insert	Ersatzteile Spare parts												
	d	h	L	f	D min		Spannpratze	Spannschraube	Unterlage	Stift	Unterlegscheibe	Winkelschlüssel							
							Clamp	Clamping screw	Shim	Pin	Washer	Allen key							
S20R MCLNR/L 12	20	18	200	13	≥25														
S25S MCLNR/L 12	25	23	250	17	≥32								CNM. 12 04..	002007	003004	001013	007004	-	017003
S32T MCLNR/L 12	32	30	300	22	≥40														

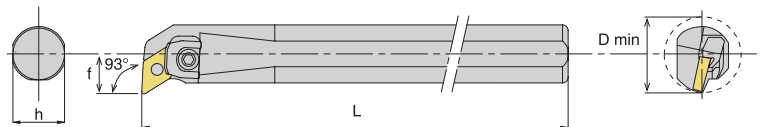

Bezeichnung Designation	Abmessungen (mm) Dimensions (mm)					Wendeplatte Insert	Ersatzteile Spare parts												
	d	h	L	f	D min		Spannpratze	Spannschraube	Unterlage	Stift	Unterlegscheibe	Winkelschlüssel							
							Clamp	Clamping screw	Shim	Pin	Washer	Allen key							
S20R MDUNR/L 11	20	18	200	13	≥25														
S25S MDUNR/L 11	25	23	250	17	≥32								DNM. 11 04..	002007	003004	-	007003	-	017003
S32T MDUNR/L 11	32	30	300	22	≥40														
S25S MDUNR/L 15	25	23	250	17	≥32	DNM. 15 06..	002008	003002	001030	007004	005001	017003							
S32T MDUNR/L 15	32	30	300	22	≥40														
S40U MDUNR/L 15	40	37	350	27	≥50														
S50V MDUNR/L 15	50	47	400	35	≥63														

Bestellbeispiel/Ordering example: 1 Stk/pcs. S20R MDUNR 11

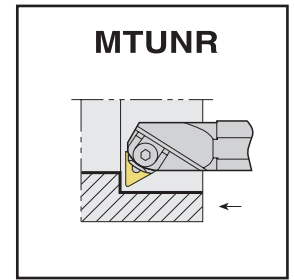
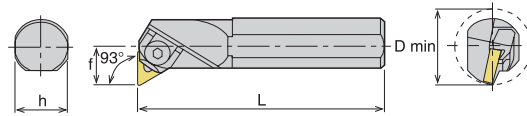

Bezeichnung Designation	Abmessungen (mm) Dimensions (mm)					Wendeplatte Insert	Ersatzteile Spare parts							
	d	h	L	f	D min		Spannpratze Clamp	Spannschraube Clamping screw	Unterlage Shim	Stift Pin	Unterlegscheibe Washer	Winkelschlüssel Allen key		
S20R MTUNR/L 16	20	18	200	13	≥25	TNM. 16 04..	002006	003004	-	007003	-	017003		
S25S MTUNR/L 16	25	23	250	17	≥32				001002	007001	005001			
S32T MTUNR/L 16	32	30	300	22	≥40				002008	003002			001004	007002
S40U MTUNR/L 16	40	37	350	27	≥50									
S32T MTUNR/L 22	32	30	300	22	≥40	TNM. 22 04..	002008	003002	-	007003	-	017003		
S40U MTUNR/L 22	40	37	350	27	≥50				001002	007001	005001			
S40U MTUNR/L 22	40	37	350	27	≥50				002008	003002			001004	007002
S50V MTUNR/L 22	50	47	400	35	≥63									

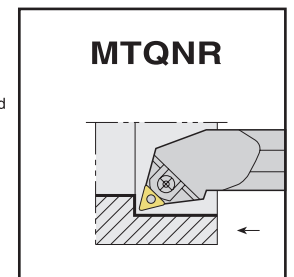
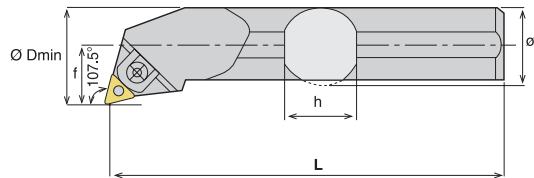

Bezeichnung Designation	Abmessungen (mm) Dimensions (mm)					Wendeplatte Insert	Ersatzteile Spare parts							
	d	h	L	f	D min		Spannpratze Clamp	Spannschraube Clamping screw	Unterlage Shim	Stift Pin	Unterlegscheibe Washer	Winkelschlüssel Allen key		
S20R MTQNR/L 16	20	18	200	13	≥25	TNM. 16 04..	002006	003004	-	007003	-	017003		
S25S MTQNR/L 16	25	23	250	17	≥32				001002	007001	005001			
S32T MTQNR/L 16	32	30	300	22	≥40				002008	003002			001004	007002
S40U MTQNR/L 16	40	37	350	27	≥50									
S32T MTQNR/L 22	32	30	300	22	≥40	TNM. 22 04..	002008	003002	-	007003	-	017003		
S40U MTQNR/L 22	40	37	350	27	≥50				001002	007001	005001			
S40U MTQNR/L 22	40	37	350	27	≥50				002008	003002			001004	007002
S50V MTQNR/L 22	50	47	400	35	≥63									

Bestellbeispiel/Ordering example: 1 Stk/pcs. S20R MTQNR 16

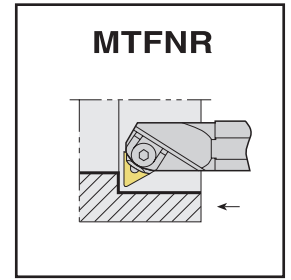
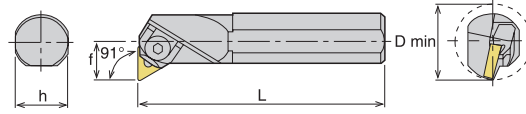

Bezeichnung Designation	Abmessungen (mm) Dimensions (mm)					Wendeplatte Insert	Ersatzteile Spare parts					
	d	h	L	f	D min		Spannpratze Clamp	Spannschraube Clamping screw	Unterlage Shim	Stift Pin	Unterlegscheibe Washer	Winkelschlüssel Allen key
									-	-	-	-
S20R MTFNR/L 16	20	18	200	13	≥25	TNM. 16 04..	002006	003004	-	007003	-	017003
S25S MTFNR/L 16	25	23	250	17	≥32				001002	007001	005001	
S32T MTFNR/L 16	32	30	300	22	≥40				002008	003002		
S40U MTFNR/L 16	40	37	350	27	≥50	TNM. 22 04..	002008	003002			-	007003
S32T MTFNR/L 22	32	30	300	22	≥40				001002	007001	005001	
S40U MTFNR/L 22	40	37	350	27	≥50				001004	007002		
S50V MTFNR/L 22	50	47	400	35	≥63							

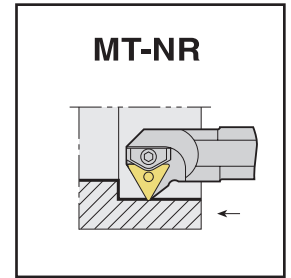
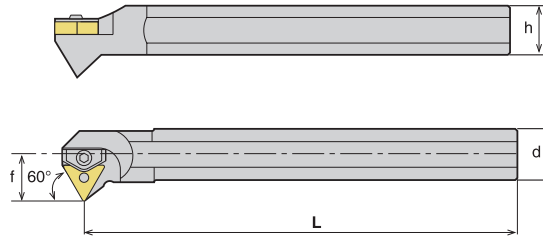

Bezeichnung Designation	Abmessungen (mm) Dimensions (mm)					Wendeplatte Insert	Ersatzteile Spare parts					
	d	h	L	f	D min		Spannpratze Clamp	Spannschraube Clamping screw	Unterlage Shim	Stift Pin	Unterlegscheibe Washer	Winkelschlüssel Allen key
									-	-	-	-
S20R MT-NR/L 16	20	18	200	13	≥25	TNM. 16 04..	002006	003004	-	007003	-	017003
S25S MT-NR/L 16	25	23	250	17	≥32				001002	007001	005001	
S32T MT-NR/L 16	32	30	300	22	≥40				002008	003002		
S40U MT-NR/L 16	40	37	350	27	≥50	TNM. 22 04..	002008	003002			-	007003
S40U MT-NR/L 22	40	37	350	27	≥50				001002	007001	005001	
									001004	007002		

Bestellbeispiel/Ordering example: 1 Stk/pcs. S20R MT-NR 16

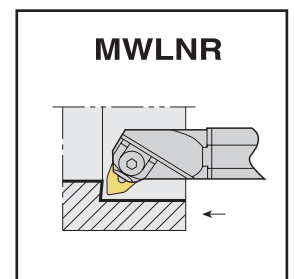
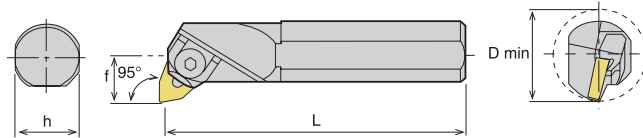







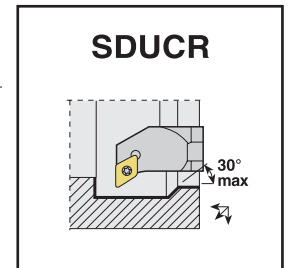
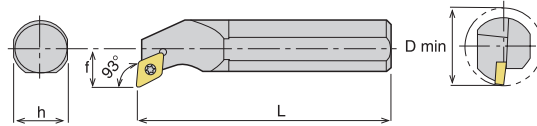

Bezeichnung Designation	Abmessungen (mm) Dimensions (mm)					Wendeplatte Insert	Ersatzteile Spare parts					
	d	h	L	f	D min		Spannpratze Clamp	Spannschraube Clamping screw	Unterlage Shim	Stift Pin	Unterlegscheibe Washer	Winkelschlüssel Allen key
S16P MWLNR/L 06	16	15	170	11	≥21		002005	003016	-	007003	-	017003
S20R MWLNR/L 06	20	18	200	13	≥25			003004				
S25S MWLNR/L 06	25	23	250	17	≥32							
S25S MWLNR/L 08	25	23	250	17	≥32		002009	003003	001017	007002	005001	017003
S32T MWLNR/L 08	32	30	300	22	≥40							
S40U MWLNR/L 08	40	37	350	27	≥50							

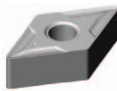
Bestellbeispiel/Ordering example: 1 Stk/pcs. S16P MWLNR 06

S-System Innendrehhalter /
S-System internal toolholders





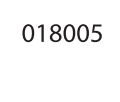



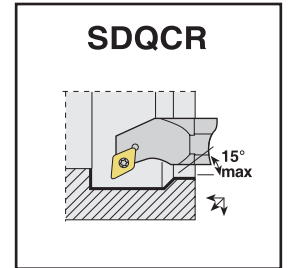
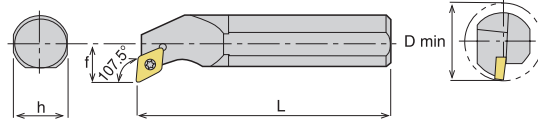

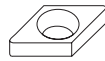

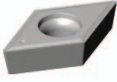

Bezeichnung Designation	Abmessungen (mm) Dimensions (mm)					Wendeplatte Insert	Ersatzteile Spare parts			
	d	h	L	f	D min		Spannschraube Clamping screw	Unterlage (UL) Shim	Schraube für UL Screw for shim	Torx Schlüssel Torx key
S10K SDUCR/L 07	10	09	125	07	≥13					
S12K SDUCR/L 07	12	11	125	09	≥16					
S16P SDUCR/L 07	16	15	170	11	≥21					
S20R SDUCR/L 07	20	18	200	13	≥25					
A10H SDUCR/L 07	10	09	100	07	≥13					
A12H SDUCR/L 07	12	11	100	09	≥16					
A16M SDUCR/L 07	16	15	150	11	≥21					
A20P SDUCR/L 07	20	18	170	13	≥25					
S16P SDUCR/L 11	16	15	170	11	≥21					
S20R SDUCR/L 11	20	18	200	13	≥25					
S25S SDUCR/L 11	25	23	250	17	≥32					
S32T SDUCR/L 11	32	30	300	22	≥40					
S40U SDUCR/L 11	40	37	350	27	≥50					
A16M SDUCR/L 11	16	15	150	11	≥21					
A20P SDUCR/L 11	20	18	170	13	≥25					
A25R SDUCR/L 11	25	23	200	17	≥32					
A32S SDUCR/L 11	32	30	250	22	≥40					

Bestellbeispiel/Ordering example: 1 Stk/pcs. S10K SDUCR 07



Bezeichnung Designation	Abmessungen (mm) Dimensions (mm)					Wendeplatte Insert	Ersatzteile Spare parts			
	d	h	L	f	D min		Spannschraube Clamping screw	Unterlage (UL) Shim	Schraube für UL Screw for shim	Torx Schlüssel Torx key
										
S10K SDQCR/L 07	10	09	125	07	≥13	DCM. 07 02.. 	011007 	-	-	018003 
S12K SDQCR/L 07	12	11	125	09	≥16					
S16P SDQCR/L 07	16	15	170	11	≥21					
S20R SDQCR/L 07	20	18	200	13	≥25					
A10H SDQCR/L 07	10	09	100	07	≥13					
A12H SDQCR/L 07	12	11	100	09	≥16					
A16M SDQCR/L 07	16	15	150	11	≥21					
A20P SDQCR/L 07	20	18	170	13	≥25					
S16P SDQCR/L 11	16	15	170	11	≥21	DCM. 11 T3.. 	011014 	-	-	018005 
S20R SDQCR/L 11	20	18	200	13	≥25					
S25S SDQCR/L 11	25	23	250	17	≥32					
S32T SDQCR/L 11	32	30	300	22	≥40					
S40U SDQCR/L 11	40	37	350	27	≥50					
A16M SDQCR/L 11	16	15	150	11	≥21					
A20P SDQCR/L 11	20	18	170	13	≥25					
A25R SDQCR/L 11	25	23	200	17	≥32					
A32S SDQCR/L 11	32	30	250	22	≥40	011042 	001028 	004006 		

Bestellbeispiel/Ordering example: 1 Stk/pcs. S10K SDQCR 07

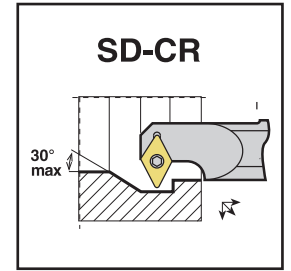
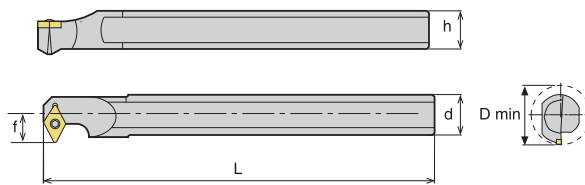

Bezeichnung Designation	Abmessungen (mm) Dimensions (mm)					Wendeplatte Insert	Ersatzteile Spare parts			
	d	h	L	f	D min		Spanschraube Clamping screw	Unterlage (UL) Shim	Schraube für UL Screw for shim	Torx Schlüssel Torx key
S12K SD-CR/L 07	12	11	125	09	≥17	DCM. 07 02..	011007	-	-	018003
S16P SD-CR/L 07	16	15	170	11	≥21					
S20R SD-CR/L 07	20	18	200	13	≥25					
S16P SD-CR/L 11	16	15	170	11	≥21	DCM. 11 T3..	011014	-	-	018005
S20R SD-CR/L 11	20	18	200	13	≥25					
S25S SD-CR/L 11	25	23	250	17	≥32					
S32T SD-CR/L 11	32	30	300	22	≥40					
S40U SD-CR/L 11	40	37	350	27	≥50		011042	001028	004006	

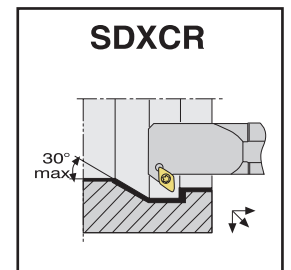
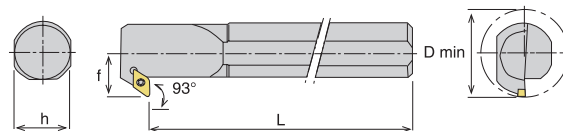

Bezeichnung Designation	Abmessungen (mm) Dimensions (mm)					Wendeplatte Insert	Ersatzteile Spare parts			
	d	h	L	f	D min		Spanschraube Clamping screw	Unterlage (UL) Shim	Schraube für UL Screw for shim	Torx Schlüssel Torx key
S12K SDXCR/L 07	12	11	125	09	≥17	DCM. 07 02..	011007	-	-	018003
S16P SDXCR/L 07	16	15	170	11	≥21					
S20R SDXCR/L 07	20	18	200	13	≥25					
S16P SDXCR/L 11	16	15	170	11	≥21	DCM. 11 T3..	011014	-	-	018005
S20R SDXCR/L 11	20	18	200	13	≥25					
S25S SDXCR/L 11	25	23	250	17	≥32					
S32T SDXCR/L 11	32	30	300	22	≥40					
S40U SDXCR/L 11	40	37	350	27	≥50		011042	001028	004006	

Bestellbeispiel/Ordering example: 1 Stk./pcs. S12K SDXCR 07

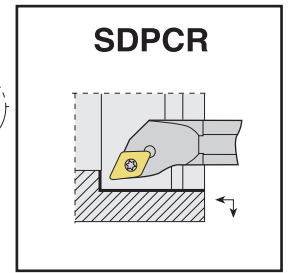
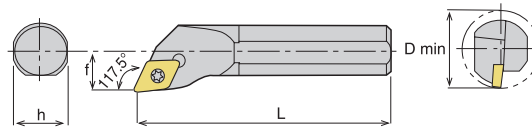

Bezeichnung Designation	Abmessungen (mm) Dimensions (mm)					Wendeplatte Insert	Ersatzteile Spare parts			
	d	h	L	f	D min		Spannschraube Clamping screw	Unterlage (UL) Shim	Schraube für UL Screw for shim	Torx Schlüssel Torx key
S10K SDPCR/L 07	10	09	125	07	≥13		011007	-	-	018003
S12K SDPCR/L 07	12	11	125	09	≥16					
S16P SDPCR/L 11	16	15	170	11	≥21		011014	-	-	018005
S20R SDPCR/L 11	20	18	200	13	≥25					
S25S SDPCR/L 11	25	23	250	17	≥32					

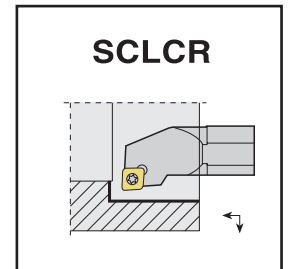
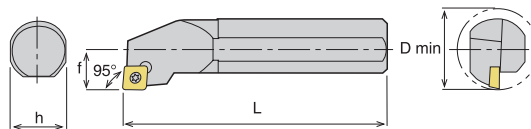

Bezeichnung Designation	Abmessungen (mm) Dimensions (mm)					Wendeplatte Insert	Ersatzteile Spare parts							
	d	h	L	f	D min		Spannschraube Clamping screw	Unterlage (UL) Shim	Schraube für UL Screw for shim	Torx Schlüssel Torx key				
S0608H SCLCR/L 06	06	07	100	4,5	≥8		011006	-	-	018003				
S08H SCLCR/L 06	08	07	100	06	≥11		011007							
S10K SCLCR/L 06	10	09	125	07	≥13		011006							
S12K SCLCR/L 06	12	11	125	09	≥16		011007							
A08H SCLCR/L 06	08	07	100	06	≥11		011006							
A10H SCLCR/L 06	10	09	100	07	≥13		011007							
S12K SCLCR/L 09	12	11	125	09	≥16		011014	-	-	018005				
S16P SCLCR/L 09	16	15	170	11	≥21		011042				001011	004006		
S20R SCLCR/L 09	20	19	200	13	≥25		011014				-	-		
S25S SCLCR/L 09	25	23	250	17	≥32		011042						001011	004006
S32T SCLCR/L 09	32	30	300	22	≥40		011014						-	-
A16M SCLCR/L 09	16	15	150	11	≥21		011042				001011	004006		
A20P SCLCR/L 09	20	19	170	13	≥25		011042				001011	004006		
A25R SCLCR/L 09	25	23	200	17	≥32		011037	001012	004007	018006				
A32S SCLCR/L 09	32	30	250	22	≥40									
S25S SCLCR/L 12	25	23	250	17	≥32									
S32T SCLCR/L 12	32	30	300	22	≥40									
S40U SCLCR/L 12	40	37	350	27	≥50									
A25R SCLCR/L 12	25	23	200	17	≥32									

Bestellbeispiel/Ordering example: 1 Stk/pcs. S0608H SCLCR 06

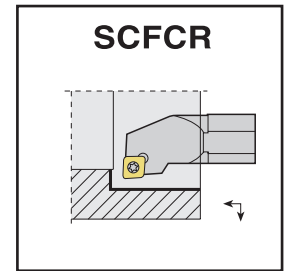
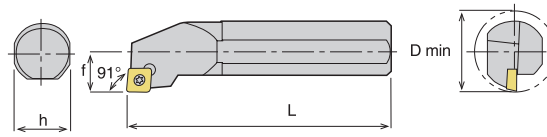

Bezeichnung Designation	Abmessungen (mm) Dimensions (mm)					Wendeplatte Insert	Ersatzteile Spare parts								
	d	h	L	f	D min		Spannschraube Clamping screw	Unterlage (UL) Shim	Schraube für UL Screw for shim	Torx Schlüssel Torx key					
S08H SCFCR/L 06	08	07	100	06	≥11										
S10K SCFCR/L 06	10	09	125	07	≥13		CCM. 06 02..	011006	-		-	018003			
S12K SCFCR/L 06	12	11	125	09	≥16			011007	-		-				
S16P SCFCR/L 09	16	15	170	11	≥21										
S20R SCFCR/L 09	20	19	200	13	≥25						CCM. 09 T3..	011014	-	-	018005
S25S SCFCR/L 09	25	23	250	17	≥32							011042	001011	004006	
S25S SCFCR/L 12	25	23	250	17	≥32										
S32T SCFCR/L 12	32	30	300	22	≥40						CCM. 12 04..	011037	001012	004007	018006
S40U SCFCR/L 12	40	37	350	27	≥50										

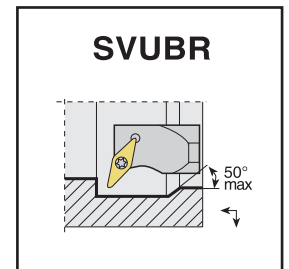
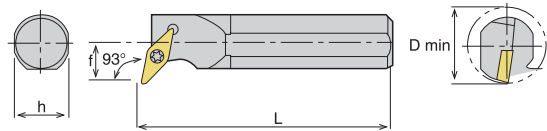

Bezeichnung Designation	Abmessungen (mm) Dimensions (mm)					Wendeplatte Insert	Ersatzteile Spare parts								
	d	h	L	f	D min		Spannschraube Clamping screw	Unterlage (UL) Shim	Schraube für UL Screw for shim	Torx Schlüssel Torx key					
S16P SVUBR/L 11	16	15	170	11	≥21										
S20R SVUBR/L 11	20	18	200	13	≥25						VBM. 11 03..	011007	-	-	018003
S25S SVUBR/L 16	25	23	250	17	≥32										
S32T SVUBR/L 16	32	30	300	22	≥40										
S40U SVUBR/L 16	40	37	350	27	≥50						VBM. 16 04..	011042	001032	004006	018005

Bestellbeispiel/Ordering example: 1 Stk/pcs. S16P SVUBR 11

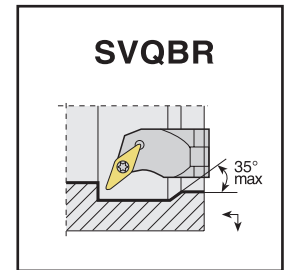
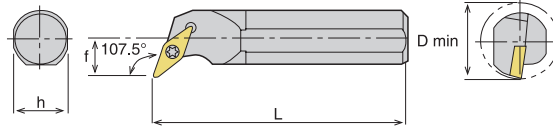

Bezeichnung Designation	Abmessungen (mm) Dimensions (mm)					Wendeplatte Insert	Ersatzteile Spare parts			
	d	h	L	f	D min		Spanschraube Clamping screw	Unterlage (UL) Shim	Schraube für UL Screw for shim	Torx Schlüssel Torx key
S16P SVQBR/L 11 S20R SVQBR/L 11	16 20	15 18	170 200	11 13	≥21 ≥25	VBM. 11 03..	011007	-	-	018003
S25S SVQBR/L 16 S32T SVQBR/L 16 S40U SVQBR/L 16	25 32 40	23 30 37	250 300 350	17 22 27	≥32 ≥40 ≥50					

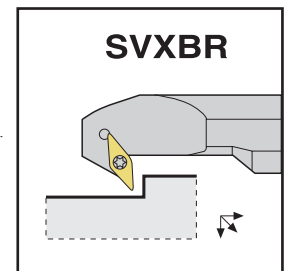
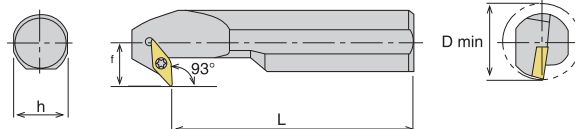

Bezeichnung Designation	Abmessungen (mm) Dimensions (mm)					Wendeplatte Insert	Ersatzteile Spare parts			
	d	h	L	f	D min		Spanschraube Clamping screw	Unterlage (UL) Shim	Schraube für UL Screw for shim	Torx Schlüssel Torx key
S16P SVXBR/L 11 S20R SVXBR/L 11	16 20	15 18	170 200	11 13	≥21 ≥25	VBM. 11 03..	011007	-	-	018003
S25S SVXBR/L 16 S32T SVXBR/L 16 S40U SVXBR/L 16	25 32 40	23 30 37	250 300 350	17 22 27	≥32 ≥40 ≥50					

Bestellbeispiel/Ordering example: 1 Stk./pcs. S16P SVXBR 11

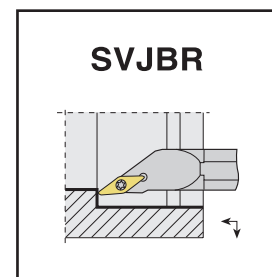
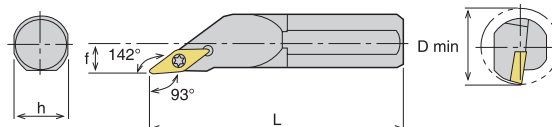

Bezeichnung Designation	Abmessungen (mm) Dimensions (mm)					Wendeplatte Insert	Ersatzteile Spare parts			
	d	h	L	f	D min		Spannschraube Clamping screw	Unterlage (UL) Shim	Schraube für UL Screw for shim	Torx Schlüssel Torx key
S25S SVJBR/L 16	25	23	250	17	≥32					
S32T SVJBR/L 16	32	30	300	22	≥40					
S40U SVJBR/L 16	40	37	350	27	≥50					
						VBM. 16 04..	011042	001032	004006	018005

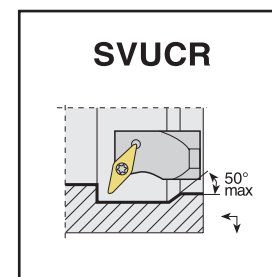
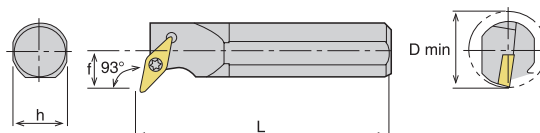

Bezeichnung Designation	Abmessungen (mm) Dimensions (mm)					Wendeplatte Insert	Ersatzteile Spare parts			
	d	h	L	f	D min		Spannschraube Clamping screw	Unterlage (UL) Shim	Schraube für UL Screw for shim	Torx Schlüssel Torx key
S16P SVUCR/L 11	16	15	170	11	≥21					
S20R SVUCR/L 11	20	18	200	13	≥25					
S25S SVUCR/L 16	25	23	250	17	≥32					
S32T SVUCR/L 16	32	30	300	22	≥40	VCM. 16 04..	011042	001032	004006	018005
S40U SVUCR/L 16	40	37	350	27	≥50					

Bestellbeispiel/Ordering example: 1 Stk/pcs. S16P SVUCR 11

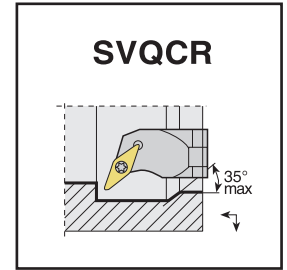
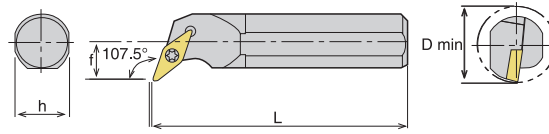

Bezeichnung Designation	Abmessungen (mm) Dimensions (mm)					Wendeplatte Insert	Ersatzteile Spare parts			
	d	h	L	f	D min		Spannschraube Clamping screw	Unterlage (UL) Shim	Schraube für UL Screw for shim	Torx Schlüssel Torx key
S16P SVQCR/L 11	16	15	170	11	≥21			-	-	
S20R SVQCR/L 11	20	18	200	13	≥25					
S25S SVQCR/L 16	25	23	250	17	≥32			001032	004006	
S32T SVQCR/L 16	32	30	300	22	≥40					
S40U SVQCR/L 16	40	37	350	27	≥50					

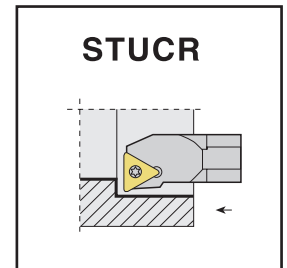
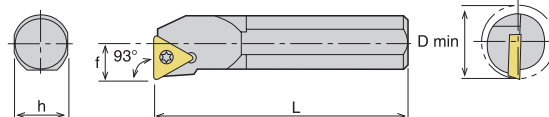

Bezeichnung Designation	Abmessungen (mm) Dimensions (mm)					Wendeplatte Insert	Ersatzteile Spare parts			
	d	h	L	f	D min		Spannschraube Clamping screw	Unterlage (UL) Shim	Schraube für UL Screw for shim	Torx Schlüssel Torx key
S10K STUCR/L 09	10	9	125	07	≥13			-	-	
S12K STUCR/L 09	12	11	125	09	≥17					
S12K STUCR/L 11	12	11	125	09	≥17			-	-	
S16P STUCR/L 11	16	15	170	11	≥21					
S20R STUCR/L 11	20	18	200	13	≥25					
S16P STUCR/L 16	16	15	170	11	≥21			-	-	
S20R STUCR/L 16	20	18	200	13	≥25					
S25S STUCR/L 16	25	23	250	17	≥32					
S32T STUCR/L 16	32	30	300	22	≥40					
S40U STUCR/L 16	40	37	350	27	≥50					

Bestellbeispiel/Ordering example: 1 Stk/pcs. S10K STUCR 09

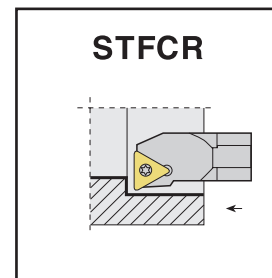
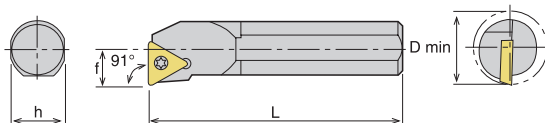



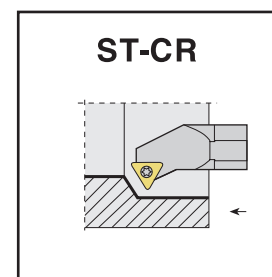
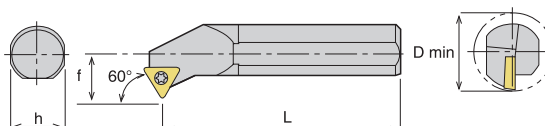



Bezeichnung Designation	Abmessungen (mm) Dimensions (mm)					Wendeplatte Insert	Ersatzteile Spare parts			
	d	h	L	f	D min		Spannschraube Clamping screw	Unterlage (UL) Shim	Schraube für UL Screw for shim	Torx Schlüssel Torx key
S0610FSTFCR/L 06	10	9	125	04	≥08					
S10K STFCR/L 09	10	9	125	07	≥13					
S12K STFCR/L 09	12	11	125	09	≥17			-	-	
S12K STFCR/L 11	12	11	125	09	≥17					
S16P STFCR/L 11	16	15	170	11	≥21			-	-	
S20R STFCR/L 11	20	18	200	13	≥25					
S16P STFCR/L 16	16	15	170	11	≥21					
S20R STFCR/L 16	20	18	200	13	≥25					
S25S STFCR/L 16	25	23	250	17	≥32					
S32T STFCR/L 16	32	30	300	22	≥40					
S40U STFCR/L 16	40	37	350	27	≥50					

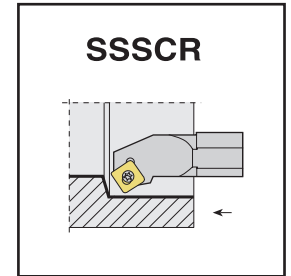
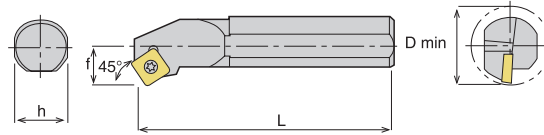
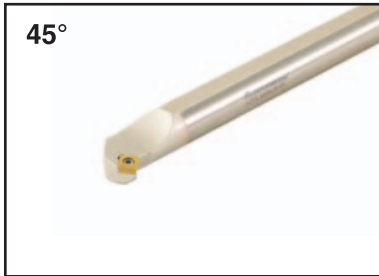



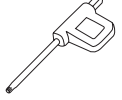

Bezeichnung Designation	Abmessungen (mm) Dimensions (mm)					Wendeplatte Insert	Ersatzteile Spare parts			
	d	h	L	f	D min		Spannschraube Clamping screw	Unterlage (UL) Shim	Schraube für UL Screw for shim	Torx Schlüssel Torx key
S12K ST-CR/L 11	12	11	125	09	≥17			-	-	
S16P ST-CR/L 11	16	15	170	11	≥21					
S20R ST-CR/L 11	20	18	200	13	≥25			-	-	
S16P ST-CR/L 16	16	15	170	11	≥21					
S20R ST-CR/L 16	20	18	200	13	≥25					
S25S ST-CR/L 16	25	23	250	17	≥32					
S32T ST-CR/L 16	32	30	300	22	≥40					
S40U ST-CR/L 16	40	37	350	27	≥50					

Bestellbeispiel/Ordering example: 1 Stk/pcs. S12K ST-CR 11

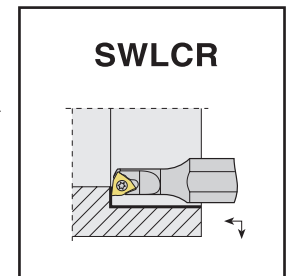
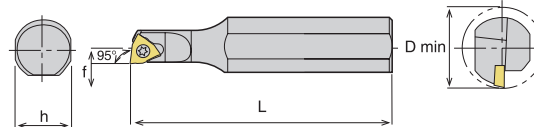

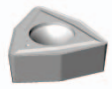
Bezeichnung Designation	Abmessungen (mm) Dimensions (mm)					Wendeplatte Insert	Ersatzteile Spare parts							
	d	h	L	f	D min		Spannschraube Clamping screw	Unterlage (UL) Shim	Schraube für UL Screw for shim	Torx Schlüssel Torx key				
S16P SSSCR/L 09	16	15	170	11	≥21									
S20R SSSCR/L 09	20	18	200	13	≥25						011014	-	-	018005
S25S SSSCR/L 09	25	23	250	17	≥32						011042	001021	004006	
S32T SSSCR/L 12	32	30	300	22	≥40		011037	001022	004007	018006				
S40U SSSCR/L 12	40	37	350	27	≥50									

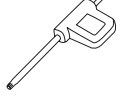

Bezeichnung Designation	Abmessungen (mm) Dimensions (mm)					Wendeplatte Insert	Ersatzteile Spare parts			
	d	h	L	f	D min		Spannschraube Clamping screw	Unterlage (UL) Shim	Schraube für UL Screw for shim	Torx Schlüssel Torx key
S0608H SWLCR 03	08	05	100	04	≥08					
S0810K SWLCR 03	10	07	125	07	≥10					

Bestellbeispiel/Ordering example: 1 Stk/pcs, S0608H SWLCR 03

P-System Innendrehhalter /
P-System internal toolholders



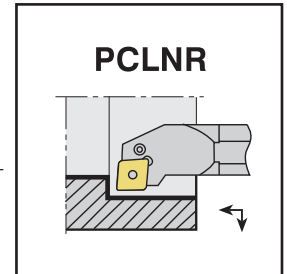
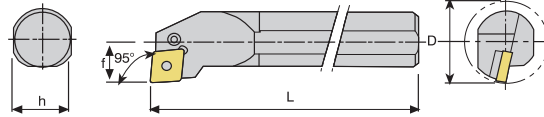

Bezeichnung Designation	Abmessungen (mm) Dimensions (mm)					Wendeplatte Insert	Ersatzteile Spare parts						
	d	h	L	f	D min		Hebel (H) Lever	Schraube für H Screw for lever	Unterlage (UL) Shim	Druckfeder für UL Pressure spring	Spannpratze Clamp	Spannschraube Clamping screw	Winkelschlüssel Allen key
S16P PCLNR/L 09	16	15	170	11	≥21	CNM. 09 03..							
S20R PCLNR/L 09	20	18	200	13	≥25								
S25S PCLNR/L 09	25	23	250	17	≥32								
S25S PCLNR/L 12C	25	23	250	17	≥32	CNM. 12 04..							
S32T PCLNR/L 12C	32	30	300	22	≥40								
S40U PCLNR/L 12C	40	37	350	27	≥50								
S50V PCLNR/L 12C	50	47	400	35	≥63								
A25R PCLNR/L 12C	25	23	200	17	≥32								
A32S PCLNR/L 12C	32	30	250	22	≥40								
A40T PCLNR/L 12C	40	37	300	27	≥50	CNM. 16 06..							
A50U PCLNR/L 12C	50	47	350	35	≥63								
S32T PCLNR/L 16	32	30	300	22	≥40								
S40U PCLNR/L 16	40	37	350	27	≥50								
S50V PCLNR/L 16	50	47	400	35	≥63								
A32S PCLNR/L 16C	32	30	250	22	≥40								
A40T PCLNR/L 16	40	37	300	27	≥50	CNM. 19 06..							
A50U PCLNR/L 16C	50	47	350	35	≥63								
S40U PCLNR/L 19C	40	37	350	27	≥50								
S50V PCLNR/L 19C	50	47	400	35	≥63								
A40T PCLNR/L 19C	40	37	300	27	≥50								
A50U PCLNR/L 19C	50	47	350	35	≥63								

Bestellbeispiel/Ordering example: 1 Stk./pcs. S16P PCLNR 09

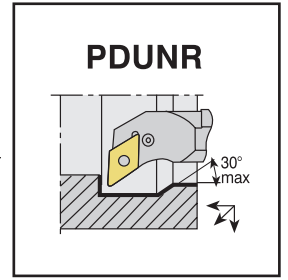
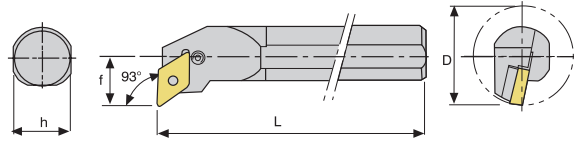

Bezeichnung Designation	Abmessungen (mm) Dimensions (mm)					Wendeplatte Insert	Ersatzteile Spare parts						
	d	h	L	f	D min		Hebel (H) Lever	Schraube für H Screw for lever	Unterlage (UL) Shim	Druckfeder für UL Pressure spring	Spannpratze Clamp	Spannschraube Clamping screw	Winkelschlüssel Allen key
S20R PDUNR/L 11	20	18	200	13	≥25	DNM. 11 04..							
S25S PDUNR/L 11	25	23	250	17	≥32								
A20P PDUNR/L 11	20	18	170	13	≥25								
A25R PDUNR/L 11	25	23	200	17	≥32								
S32T PDUNR/L 15	32	30	300	22	≥40	DNM. 15 06..							
S40U PDUNR/L 15	40	37	350	27	≥50								
S50V PDUNR/L 15	50	47	400	35	≥63								
A32S PDUNR/L 15	32	30	250	22	≥40								
A40T PDUNR/L 15	40	37	300	27	≥50								
A50U PDUNR/L 15	50	47	350	35	≥63								

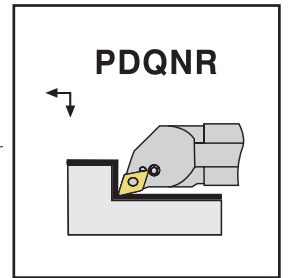
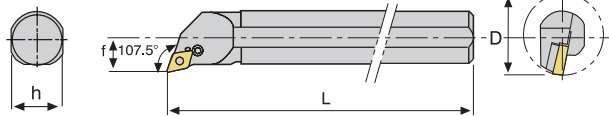

Bezeichnung Designation	Abmessungen (mm) Dimensions (mm)					Wendeplatte Insert	Ersatzteile Spare parts						
	d	h	L	f	D min		Hebel (H) Lever	Schraube für H Screw for lever	Unterlage (UL) Shim	Druckfeder für UL Pressure spring	Spannpratze Clamp	Spannschraube Clamping screw	Winkelschlüssel Allen key
S20R PDQNR/L 11	20	18	200	13	≥25	DNM. 11 04..							
S25S PDQNR/L 11	25	23	250	17	≥32								
A20P PDQNR/L 11	20	18	170	13	≥25								
A25R PDQNR/L 11	25	23	200	17	≥32								
S32T PDQNR/L 15	32	30	300	22	≥40	DNM. 15 06..							
S40U PDQNR/L 15	40	37	350	27	≥50								
S50V PDQNR/L 15	50	47	400	35	≥63								
A32S PDQNR/L 15	32	30	250	22	≥40								
A40T PDQNR/L 15	40	37	300	27	≥50								
A50U PDQNR/L 15	50	47	350	35	≥63								

Bestellbeispiel/Ordering example: 1 Stk./pcs. S20R PDQNR 11

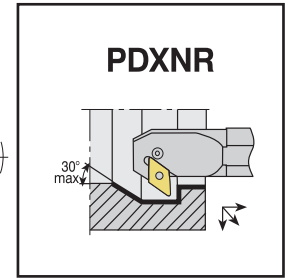
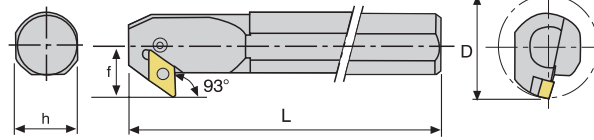

Bezeichnung Designation	Abmessungen (mm) Dimensions (mm)					Wendeplatte Insert	Ersatzteile Spare parts														
	d	h	L	f	D min		Hebel (H) Lever	Schraube für H Screw for lever	Unterlage (UL) Shim	Druckfeder für UL Pressure spring	Spannpratze Clamp	Spannschraube Clamping screw	Winkelschlüssel Allen key								
S32T PDXNR/L 15	32	30	300	25	≥45																
S40U PDXNR/L 15	40	37	350	27	≥50									DNM. 15 06..	008003	009003	001030	010002	-	-	017003
S50V PDXNR/L 15	50	47	400	35	≥63																

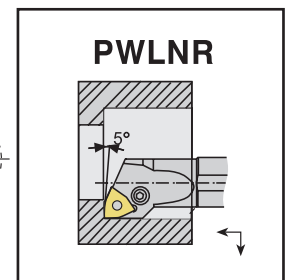
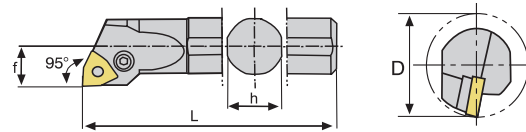

Bezeichnung Designation	Abmessungen (mm) Dimensions (mm)					Wendeplatte Insert	Ersatzteile Spare parts														
	d	h	L	f	D min		Hebel (H) Lever	Schraube für H Screw for lever	Unterlage (UL) Shim	Druckfeder für UL Pressure spring	Spannpratze Clamp	Spannschraube Clamping screw	Winkelschlüssel Allen key								
S20R PWLNR/L 06	20	18	200	13	≥25																
S25S PWLNR/L 06	25	23	250	17	≥32									WNM. 06 04..	008001	009002	001018	010001	-	-	017002
A20P PWLNR/L 06	20	18	170	13	≥25																
A25R PWLNR/L 06	25	23	200	17	≥32																
A32S PWLNR/L 06	32	30	250	22	≥40																
S25S PWLNR/L 08C	25	23	250	17	≥32	WNM. 08 04..	008002	009003	001017	010002	002014	011032	017003								
S32T PWLNR/L 08C	32	30	300	22	≥40																
S40U PWLNR/L 08C	40	37	350	27	≥50																
S50V PWLNR/L 08C	50	47	400	35	≥63																
A25R PWLNR/L 08C	25	23	200	17	≥32																
A32S PWLNR/L 08C	32	30	250	22	≥40																
A40T PWLNR/L 08C	40	37	300	27	≥50																
A50U PWLNR/L 08C	50	47	350	35	≥63																

Bestellbeispiel/Ordering example: 1 Stk/pcs. S20R PWLNR 06

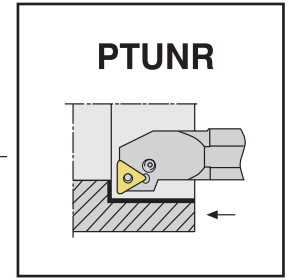
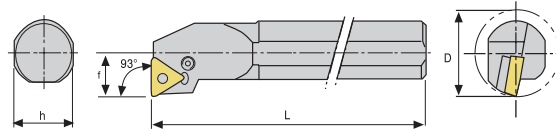

Bezeichnung Designation	Abmessungen (mm) Dimensions (mm)					Wendeplatte Insert	Ersatzteile Spare parts														
	d	h	L	f	D min		Hebel (H) Lever	Schraube für H Screw for lever	Unterlage (UL) Shim	Druckfeder für UL Pressure spring	Spannpratze Clamp	Spannschraube Clamping screw	Winkelschlüssel Allen key								
S16P PTUNR/L 16	16	15	170	11	≥21																
S20R PTUNR/L 16	20	18	200	13	≥25																
S25S PTUNR/L 16C	25	23	250	17	≥32									TNM. 16 04..	008001	009001	001003	010001	-	-	017002
S32T PTUNR/L 16C	32	30	300	22	≥40																
S40U PTUNR/L 16C	40	37	350	27	≥50														002014	011032	
S32T PTUNR/L 22C	32	30	300	22	≥40	TNM. 22 04..	008002	009003	001004	010002				017003							
S40U PTUNR/L 22C	40	37	350	27	≥50																
S50V PTUNR/L 22C	50	47	400	35	≥63																

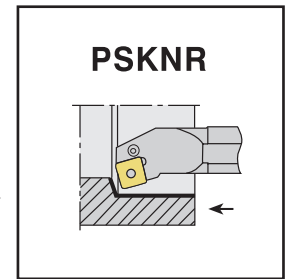
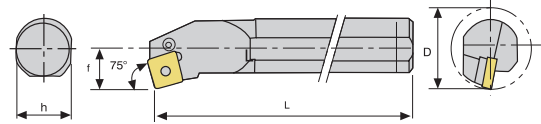

Bezeichnung Designation	Abmessungen (mm) Dimensions (mm)					Wendeplatte Insert	Ersatzteile Spare parts														
	d	h	L	f	D min		Hebel (H) Lever	Schraube für H Screw for lever	Unterlage (UL) Shim	Druckfeder für UL Pressure spring	Spannpratze Clamp	Spannschraube Clamping screw	Winkelschlüssel Allen key								
S25S PSKNR/L 12C	25	23	250	17	≥32																
S32T PSKNR/L 12C	32	30	300	22	≥40																
S40U PSKNR/L 12C	40	37	350	27	≥50									SNM. 12 04..	008002	009003	001023	010002	002014	011032	017003
S50V PSKNR/L 12C	50	47	400	35	≥63																
S32T PSKNR/L 15	32	30	300	22	≥40									SNM. 15 06..	008004	009004	001024	010003			017004
S40U PSKNR/L 15	40	37	350	27	≥50																
S50V PSKNR/L 15	50	47	400	35	≥63																

Bestellbeispiel/Ordering example: 1 Stk/pcs. S25S PSKNR 12C

Gewindedrehhalter für die Innen- und Außenbearbeitung/
Threading toolholders for internal and external machining



S **E** **R** **25 25** **M** **16** **C**

1 2 3 4-5 6 7 8

1 Art der Schneidplattenbefestigung /
Type of insert mounting

S: Über die Bohrung geschraubt
S: Screw Clamping

2 Werkzeugausführung /
Tool version

E: Außen / External
I: Innen / Internal

3 Schaftausführung /
Shaft version

R: Rechts - / Right - Hand
L: Links - / Left - Hand

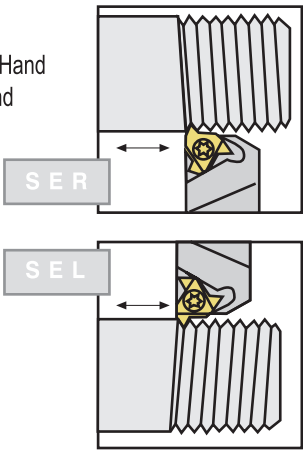

4 Grundform der Wendeschneidplatte / Basic shape of indexable insert

A: Vollstahlausführung mit innere Kühlmittelzufuhr / Solid steel design with internal coolant supply
E: Hartmetallschaft mit Kopf aus Stahl und innere Kühlmittelzufuhr / Carbide shank with steel head and supply internal coolant
C: Hartmetallschaft mit Kopf aus Stahl ohne innere Kühlmittelzufuhr / Carbide shank with steel head and without internal coolant supply
S: Vollstahlausführung ohne innere Kühlmittelzufuhr / Solid steel design without internal coolant supply

4-5 Schaftabmessung / Shank size

Schaft : hxb / Shank : hxb
2525 - 25 x 25 mm

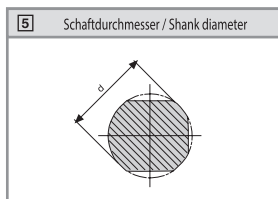

6 Drehhalterlänge (mm) / Turning toolholder length (mm)

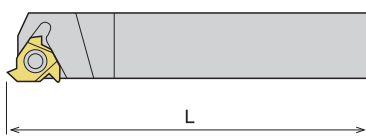

A - 32	H - 100	Q - 180	x-special
B - 40	J - 110	R - 200	
C - 50	K - 125	S - 250	
D - 60	L - 140	T - 300	
E - 70	M - 150	U - 350	
F - 80	N - 160	V - 400	
G - 90	P - 170	W - 450	

(mm)

7 Wendeplattengröße /
Insert size

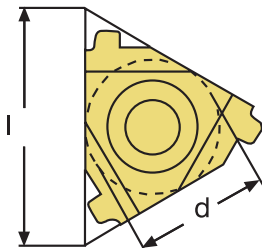



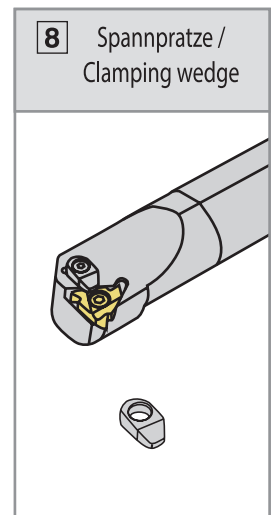



l (mm)	d
06	5/32"
08	3/16"
11	1/4"
16	3/8"
22	1/2"
27	5/8"

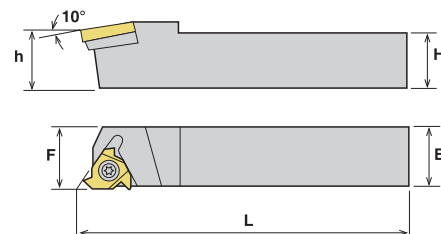
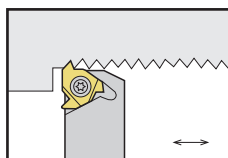

S **I** **R** **S** **25** **R** **16** **C**

1 2 3 4 5 6 7 8



Bezeichnung Designation	Abmessungen (mm) Dimensions (mm)				Wendeplatte Insert	Ersatzteile Spare parts					
	h=H	B	L	F		Spannschraube Clamping screw	Unterlage (UL) Shim	Schraube für UL Screw for shim	Spannpratze Wedge clamp	Spannschraube Clamping screw	Torx Schlüssel Torx key
											
SER/L 0808 E 11	08	08	70	11	11 ER/EL	011007	-	-	-	-	018003
SER/L 1010 E 11	10	10	70	11							
SER/L 1616 H 11	16	16	100	16							
SER/L 1616 H 16C	16	16	100	16	16 ER/EL	011042	001005	004006	002014	011032	018005
SER/L 2020 K 16C	20	20	125	20							
SER/L 2525 M 16C	25	25	150	25							
SER/L 3232 P 16C	32	32	170	32							
SER/L 2525 M 22C	25	25	150	25	22 ER/EL	011037	001006	004007			018006
SER/L 3232 P 22C	32	32	170	32							
SER/L 4040 S 22C	40	40	250	40							
SER/L 2525 M 16C-T	25	25	150	25	16 ER/L (1.5-3 TR)	011014	-	-			018005
SER/L 2525 M 22C-T	25	25	150	25	22 ER/L (4-6 TR)	011037	-	-			018006

Bestellbeispiel/Ordering Example: 1 Stk/pcs. SER 0808 E11

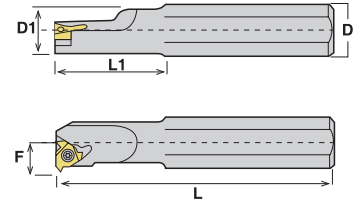
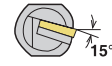
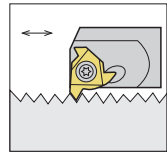

Bezeichnung Designation	Abmessungen (mm) Dimensions (mm)						Wendeplatte Insert	Ersatzteile Spare parts					
	D	D1	L	L1	F	D min		Spannschraube Clamping screw	Unterlage (UL) Shim	Schraube für UL Screw for shim	Spannpratze Wedge clamp	Spannschraube Clamping screw	Torx Schlüssel Torx key
SIR/L S16X07M 08	16	07	150	18	5.3	7.8	08 IR/L	011004	-	-	-	-	018002
SIR/L S10H 11	10	10	100	-	7.4	12	11 IR/L	011007	-	-	-	-	018003
SIR/L S12K 11	12	12	125	-	8.4	16							
SIR/L S16X10M 11	16	10	150	25	7.4	12							
SIR/L S16X13M 11	16	13	150	32	8.9	15							
SIR/L S16X13M 16	16	13	150	32	10.2	16	16 IR/L	011014	-	-	-	-	018005
SIR/L S16M 16	16	16	150	-	11.7	19							
SIR/L S20X16P 16	20	16	170	40	11.7	19							
SIR/L S20P 16	20	20	170	-	13.7	24							
SIR/L S25R 16C	25	25	200	-	16.2	29							
SIR/L S32S 16C	32	32	250	-	19.7	36							
SIR/L S40T 16C	40	40	300	-	23.7	44	16 IR/L (1.5-3 TR)	011042	001005	004006	002014	011032	018006
SIR/L S50U 16C	50	50	350	-	28.7	54							
SIR/L S20P 22	20	20	170	-	14	24							
SIR/L S25R 22C	25	25	200	-	18.1	29							
SIR/L S32S 22C	32	32	250	-	21.6	38	22 IR/L	011037	001006	004007	002014	011032	018006
SIR/L S40T 22C	40	40	300	-	25.6	46							
SIR/L S50U 22C	50	50	350	-	30.6	58	22 IR/L (4-6 TR)	011037	-	-	-	-	018006
SIR/L S25R 16C-T	25	25	200	-	16.2	29							
SIR/L S32S 16C-T	32	32	250	-	19.7	36	16 IR/L (1.5-3 TR)	011014	-	-	-	-	018005
SIR/L S25R 22C-T	25	25	200	-	18.1	29							
SIR/L S32S 22C-T	32	32	250	-	21.6	38	22 IR/L (4-6 TR)	011037	-	-	-	-	018006

Bestellbeispiel/Ordering Example: 1 Stk/pcs. SIR S16X07M 08

Kurzklemmhalter / *Cartridges*



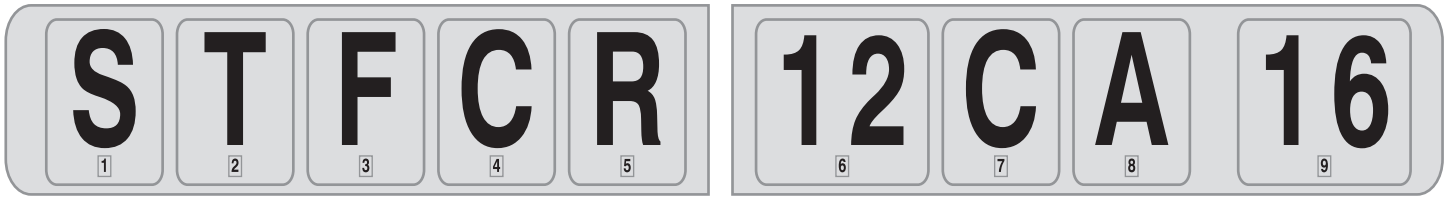



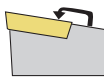
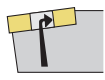
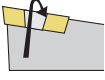

1 Art der Schneidplattenbefestigung / Type of insert mounting

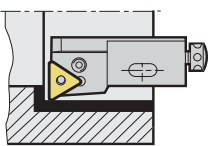
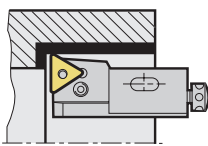
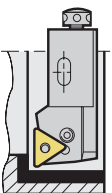
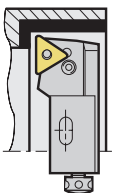
 von oben gespannt/ top clamping	 über die Bohrung gespannt/ hole clamping	 über die Bohrung geschraubt/ screw clamping
C	P	S

5 Drehhalterauführung / Orientation of turning toolholder

 R	 L
	

2 Grundform der Wendeschneidplatte / Basic shape of indexable insert

 C	 S	 T
---	---	---

3 Anstellwinkel / Approach angle

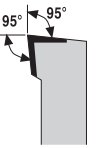
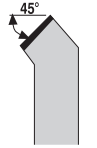
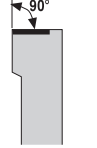
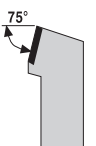
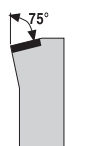
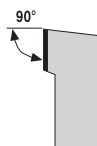
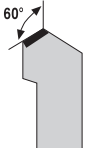
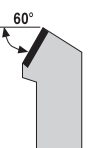
 L	 S	 F
 R	 K	 G
 W	 T	

6 Drehhalterhöhe (mm) / Turning toolholder height (mm)

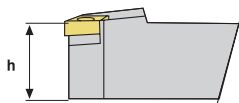

h



7 Kennzeichen für Kurzklemmhalter / Cartridge code

C
(Kurzklemmhalter / Cartridge)

8 Art des Kurzklemmhalters / Type of cartridge

A
(ISO 5611)

4 Freiwinkel der Wendeschneidplatte / Indexable insert clearance angle

 C	 P	 N
---	---	---

9 Länge der Schneidkante (mm) / Length of cutting edge (mm)

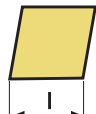
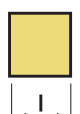
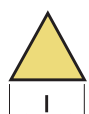
 C	 S	 T
--	---	---

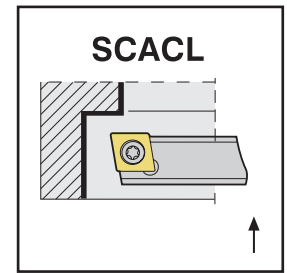
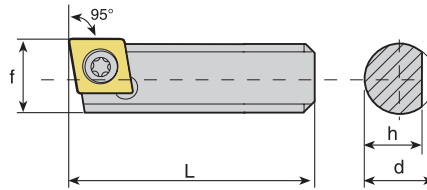

Bezeichnung Designation	Abmessungen (mm) Dimensions (mm)				Wendeplatte Insert	Ersatzteile Spare parts	
	d	h	L	f		Spannschraube Clamping screw	Torx Schlüssel Torx key
S10X SCACR/L 06	10	8.5	25	10.5			
S10A SCACR/L 06	10	8.5	32	10.5			
S10C SCACR/L 06	10	8.5	50	10.5			
S12B SCACR/L 06	12	10.5	40	12.5			
S16A SCACR/L 09	16	14	32	16.5			
S16B SCACR/L 09	16	14	40	16.5			
S16C SCACR/L 09	16	14	50	16.5			
S16D SCACR/L 09	16	14	60	16.5			
S16E SCACR/L 09	16	14	70	16.5			
S16G SCACR/L 09	16	14	90	16.5			
S16H SCACR/L 09	16	14	100	16.5			

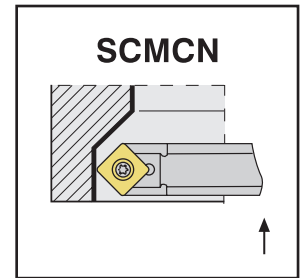
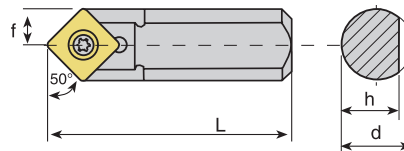

Bezeichnung Designation	Abmessungen (mm) Dimensions (mm)				Wendeplatte Insert	Ersatzteile Spare parts	
	d	h	L	f		Spannschraube Clamping screw	Torx Schlüssel Torx key
S10X SCMCN 06	10	8.5	25	5			
S16C SCMCN 09	16	14	50	8			
S16D SCMCN 09	16	14	60	8			
S16D SCMCN 09-R	16	14	60	8			
S16D SCMCN 09-L	16	14	60	8			

Bestellbeispiel/Ordering example: 1 Stk/pcs. S10X SCMCN 06

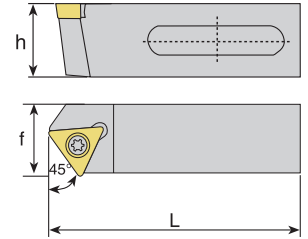



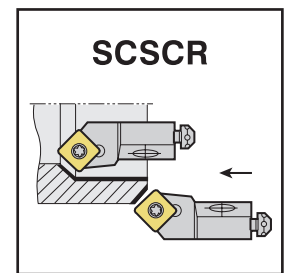
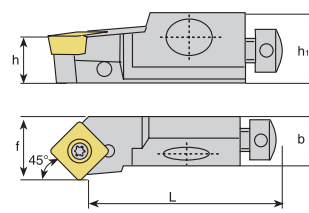
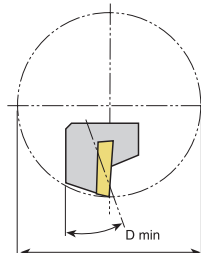
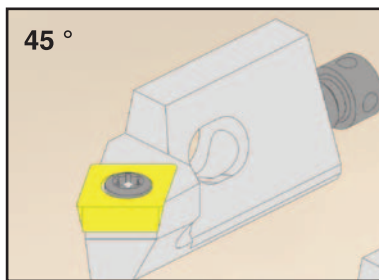



Bezeichnung Designation	Abmessungen (mm) Dimensions (mm)				Wendeplatte Insert	Ersatzteile Spare parts	
	d	h	L	f		Spannschraube Clamping screw	Torx Schlüssel Torx key
STXCR/L 2020 B16	20	20	40	20			
STXCR/L 2020 E16	20	20	70	20	TCM. 16T3..	011014	018005

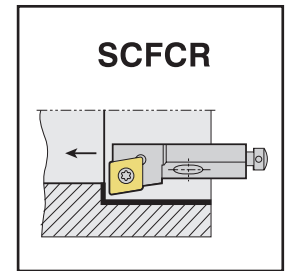
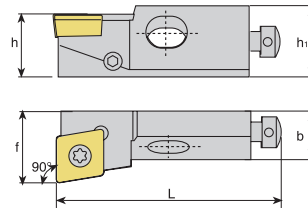
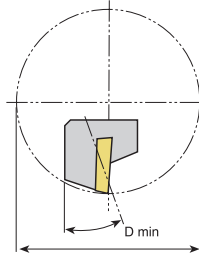





Bezeichnung Designation	Abmessungen (mm) Dimensions (mm)							Wendeplatte Insert	Ersatzteile Spare parts			
	h	h ₁	b	L	f	D min	Unterlage Shim		Schraube für Unterlage Screw for shim	Spannschraube Clamping screw	Torx Schlüssel Torx key	
SCSCR/L 06CA 06	6	8	6	21	8	≥20		-	-			
SCSCR/L 10CA 09	10	15	11	44	14	≥40	CCM. 09T3..					
SCSCR/L 12CA 12	12	18	15	47	20	≥50	CCM. 1204..					

Bestellbeispiel/Ordering example: 1 Stk/pcs. SCSCR 06CA 06

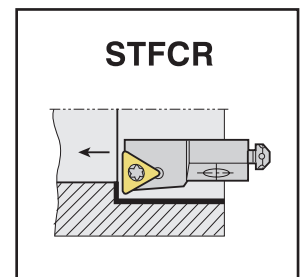
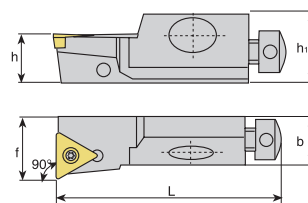
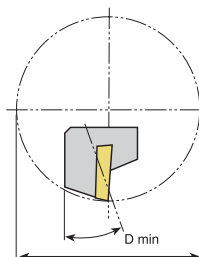

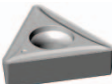

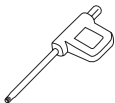

Bezeichnung Designation	Abmessungen (mm) Dimensions (mm)							Wendeplatte Insert 	Ersatzteile Spare parts			
	h	h ₁	b	L	f	D min	Unterlage Shim		Schraube für Unterlage Screw for shim	Spannschraube Clamping screw	Torx Schlüssel Torx key	
												
SCFCR/L 06CA 06	6	8.5	6	25	8	≥20	CCM. 0602..	-	-	011007	018003	
SCFCR/L 08CA 06	8	11	8	32	10	≥20		-	-	011014	018005	
SCFCR/L 10CA 09	10	15	11	50	14	≥40	CCM. 09T3..	-	-	011014	018005	
SCFCR/L 12CA 12	12	18	15	55	20	≥50		001012	004007	011037	018006	
SCFCR/L 16CA 12	16	21	20	63	25	≥60		001012	004007	011037	018006	



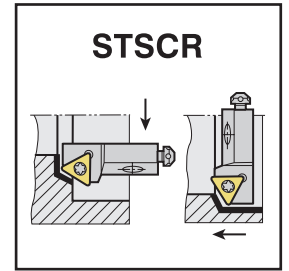
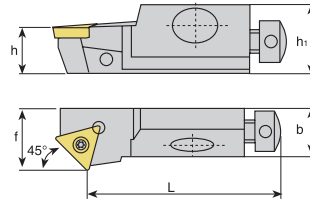
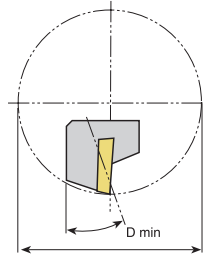

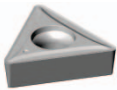

Bezeichnung Designation	Abmessungen (mm) Dimensions (mm)							Wendeplatte Insert 	Ersatzteile Spare parts			
	h	h ₁	b	L	f	D min	Unterlage Shim		Schraube für Unterlage Screw for shim	Spannschraube Clamping screw	Torx Schlüssel Torx key	
												
STFRCR/L 10CA 11	10	15	11	50	14	≥40	TCM. 1102..	-	-	011007	018003	
STFRCR/L 12CA 16	12	20	15	55	20	≥50		-	-	011014	018005	
STFRCR/L 16CA 16	16	21	20	63	20	≥60	TCM. 16T3..	001001	004006	011042	018005	

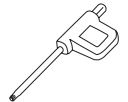
Bestellbeispiel/Ordering example: 1 Stk./pcs. STFRCR 10CA 11

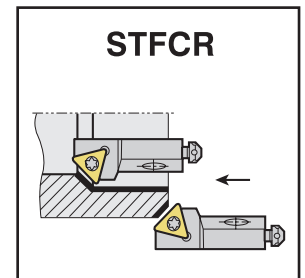
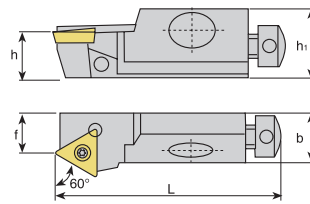
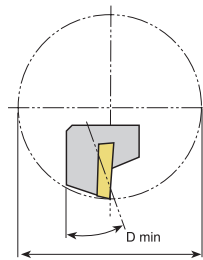
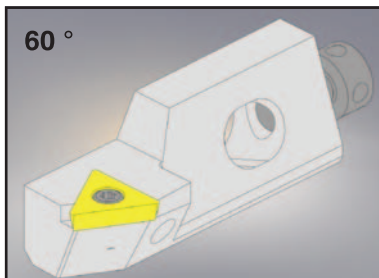

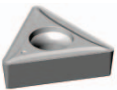



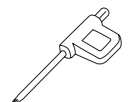

Bezeichnung Designation	Abmessungen (mm) Dimensions (mm)						Wendeplatte Insert 	Ersatzteile Spare parts			
	h	h ₁	b	L	f	D min		Unterlage Shim	Schraube für Unterlage Screw for shim	Spannschraube Clamping screw	Torx Schlüssel Torx key
											
STSCR/L 08CA 09	8	11	8	28	10	≥20	TCM. 0902..	-	-	011004	018002
STSCR/L 10CA 11	10	15	11	44	14	≥40	TCM. 1102..	-	-	011007	018003

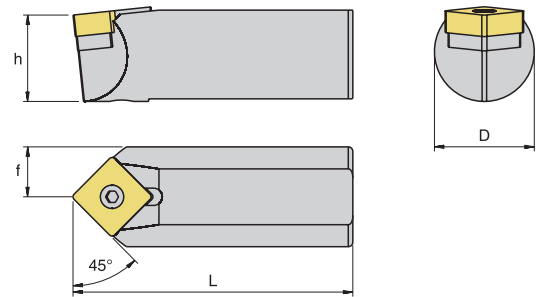

Bezeichnung Designation	Abmessungen (mm) Dimensions (mm)						Wendeplatte Insert 	Ersatzteile Spare parts			
	h	h ₁	b	L	f	D min		Unterlage Shim	Schraube für Unterlage Screw for shim	Spannschraube Clamping screw	Torx Schlüssel Torx key
											
STTCR/L 08CA 09	8	9,5	6,5	25,7	10	≥20	TCM. 0902..	-	-	011004	018002
STTCR/L 10CA 11	10	15	11	42	13,9	≥40	TCM. 1102..	-	-	011007	018003

Bestellbeispiel/Ordering example: 1 Stk/pcs, STTCR 08CA 09



Bezeichnung Designation	Abmessungen (mm) Dimensions (mm)				Wendeplatte Insert	Ersatzteile Spare parts				
	d	h	L	f		Unterlage Shim	Spannschraube Clamping screw	Spannpratze Clamp	Spannschraube Clamping screw	Winkelschlüssel Allen key
										
S22D PSDNN 12C	22	19.5	60	11		001027	013001	002014	011032	017002

Bestellbeispiel/Ordering example: 1 Stk./pcs. SS22D PSDNN 12C

Wendenplattenbohrer / *U-Drills for indexable inserts*



G **UD** **16** x **D3**

1 2 3 4

S **P** **M** **T** **06** **02** **04**

5 6 7 8 9 10 11

2 Bohrwerkzeug / Drilling tool

UD: Wendepplattenbohrer / U-drill

3 Werkzeugdurchmesser (mm) / Tool diameter (mm)

4 Bohrtiefe / Drilling depth

5 Grundform der Wendepplatte / Basic shape of indexable insert

W **S**

6 Freiwinkel der Wendeschneidplatte / indexable insert clearance angle

C **P**

8 Art der Wendepplatte / Type of insert

A $\beta = 70-90^\circ$ J $\beta = 70-90^\circ$ T $\beta = 40-60^\circ$
 B $\beta = 70-90^\circ$ M $\beta = 40-60^\circ$ U $\beta = 40-60^\circ$
 C $\beta = 70-90^\circ$ N $\beta = 40-60^\circ$ W $\beta = 40-60^\circ$
 F $\beta = 70-90^\circ$ Q $\beta = 40-60^\circ$
 G $\beta = 70-90^\circ$ R $\beta = 40-60^\circ$ X Spezial / Special
 H $\beta = 70-90^\circ$

10 Wendepplattendicke / Thickness of insert

01 s = 1.59
 T1 s = 1.98
 02 s = 2.38
 T2 s = 2.78
 03 s = 3.18
 T3 s = 3.97
 04 s = 4.76
 05 s = 5.56
 06 s = 6.35
 07 s = 7.94
 09 s = 9.52

7 Toleranzklassen / Tolerance classes

	d	m	t
A	± 0.025	± 0.005	± 0.025
C	± 0.025	± 0.013	± 0.025
E	± 0.025	± 0.025	± 0.025
F	± 0.013	± 0.005	± 0.025
G	± 0.025	± 0.025	± 0.130
H	± 0.013	± 0.013	± 0.025
J	± 0.05-0.15	± 0.005	± 0.025
K	± 0.05-0.15	± 0.013	± 0.025
L	± 0.05-0.15	± 0.025	± 0.025
M	± 0.05-0.15	± 0.08-0.20	± 0.130
N	± 0.05-0.15	± 0.08-0.20	± 0.025
U	± 0.08-0.25	± 0.13-0.38	± 0.130



d : Inkreis / Inscribed circle
 m : Gemäß Abbildung / Refer to figure
 t : Dicke / Thickness

9 Länge der Schneidkante (mm) / Length of cutting edge (mm)

11 Wendepplatten - Eckenradius / Insert corner radius

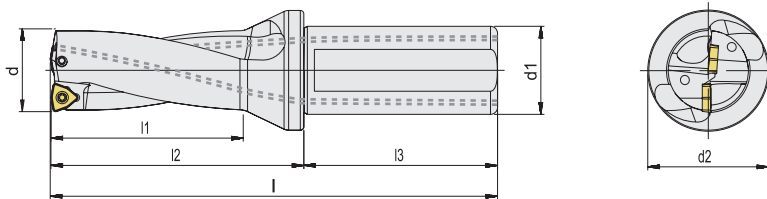

01 r = 0.1
 02 r = 0.2
 04 r = 0.4
 08 r = 0.8
 12 r = 1.2
 16 r = 1.6
 24 r = 2.4

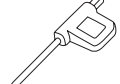

Bezeichnung Designation	Abmessungen (mm) Dimensions (mm)							Wendepplatte Insert 	Ersatzteile Spare parts	
	d	d ₁	d ₂	l	l ₁	l ₂	l ₃		Spannschraube Clamping screw 	Torx Schlüssel Torx key 
GUD 16XD2 WCM. 030208	16	25	34	108	32	52	56	WCM. 030208	011008	018003
GUD 16.5XD2 WCM. 030208	16.5	25	34	110	34	54	56			
GUD 17XD2 WCM. 030208	17	25	34	110	34	54	56			
GUD 17.5XD2 WCM. 030208	17.5	25	34	113	36	57	56			
GUD 18XD2 WCM. 030208	18	25	34	113	36	57	56			
GUD 18.5XD2 WCM. 030208	18.5	25	34	115	38	59	56			
GUD 19XD2 WCM. 030208	19	25	34	115	38	59	56			
GUD 19.5XD2 WCM. 030208	19.5	25	34	119	40	63	56			
GUD 20XD2 WCM. 040208	20	25	34	119	40	63	56	WCM. 040208	011008	018003
GUD 20.5XD2 WCM. 040208	20.5	25	34	121	42	65	56			
GUD 21XD2 WCM. 040208	21	25	34	121	42	65	56			
GUD 21.5XD2 WCM. 040208	21.5	25	34	123	44	67	56			
GUD 22XD2 WCM. 040208	22	25	34	123	44	67	56			
GUD 22.5XD2 WCM. 040208	22.5	25	34	127	46	71	56			
GUD 23XD2 WCM. 040208	23	25	34	127	46	71	56			
GUD 23.5XD2 WCM. 040208	23.5	25	34	130	48	74	56			
GUD 24XD2 WCM. 050308	24	25	34	130	48	74	56	WCM. 050308	011043	
GUD 24.5XD2 WCM. 050308	24.5	25	34	133	48	77	56			
GUD 25XD2 WCM. 050308	25	25	34	133	50	77	56			
GUD 25.5XD2 WCM. 050308	25.5	25	34	135	52	79	56			
GUD 26XD2 WCM. 050308	26	25	34	135	52	79	56			
GUD 26.5XD2 WCM. 050308	26.5	25	34	137	54	81	56			
GUD 27XD2 WCM. 050308	27	25	34	137	54	81	56			
GUD 27.5XD2 WCM. 050308	27.5	25	34	140	56	84	56			
GUD 28XD2 WCM. 050308	28	25	34	140	56	84	56			
GUD 28.5XD2 WCM. 050308	28.5	25	34	142	58	86	56			
GUD 29XD2 WCM. 050308	29	25	34	142	58	86	56			
GUD 29.5XD2 WCM. 050308	29.5	25	34	151	60	91	56			

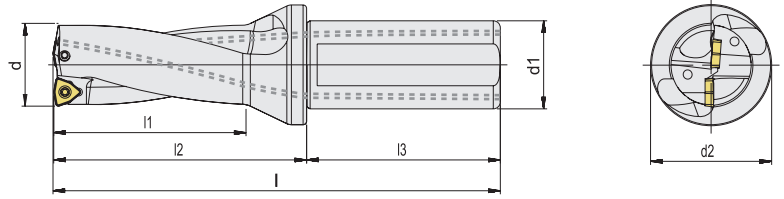
Bestellbeispiel/Ordering example: 1 Stk/pcs. GUD 16XD2 WCM. 030208

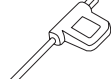

Bezeichnung Designation	Abmessungen (mm) Dimensions (mm)							Wendeplatte Insert 	Ersatzteile Spare parts	
	d	d ₁	d ₂	l	l ₁	l ₂	l ₃		Spannschraube Clamping screw 	Torx Schlüssel Torx key 
GUD 30XD2 WCM. 06T308	30	32	44	151	60	91	60	WCM. 06T308	002025	018004
GUD 31XD2 WCM. 06T308	31	32	44	154	62	94	60			
GUD 32XD2 WCM. 06T308	32	32	44	156	64	96	60			
GUD 33XD2 WCM. 06T308	33	32	44	159	66	99	60			
GUD 34XD2 WCM. 06T308	34	32	44	161	68	101	60			
GUD 35XD2 WCM. 06T308	35	32	44	164	70	104	60			
GUD 36XD2 WCM. 06T308	36	32	44	167	72	107	60			
GUD 37XD2 WCM. 06T308	37	32	44	170	74	110	60			
GUD 38XD2 WCM. 06T308	38	32	44	173	76	113	60			
GUD 39XD2 WCM. 06T308	39	32	44	175	78	115	60			
GUD 40XD2 WCM. 06T308	40	32	44	178	80	118	60			
GUD 41XD2 WCM. 06T308	41	32	44	181	82	121	60			
GUD 42XD2 WCM. 06T308	42	32	44	183	84	123	60			
GUD 43XD2 WCM. 06T308	43	32	44	186	86	126	60			
GUD 44XD2 WCM. 06T308	44	32	44	188	88	128	60			
GUD 45XD2 WCM. 080412	45	40	54	202	90	132	70			
GUD 46XD2 WCM. 080412	46	40	54	205	92	135	70			
GUD 47XD2 WCM. 080412	47	40	54	207	94	137	70			
GUD 48XD2 WCM. 080412	48	40	54	210	96	140	70			
GUD 49XD2 WCM. 080412	49	40	54	212	98	142	70			
GUD 50XD2 WCM. 080412	50	40	54	215	100	145	70			
GUD 51XD2 WCM. 080412	51	40	60	217	102	147	70			
GUD 52XD2 WCM. 080412	52	40	60	220	104	150	70			
GUD 53XD2 WCM. 080412	53	40	60	222	106	152	70			
GUD 54XD2 WCM. 080412	54	40	60	225	108	155	70			
GUD 55XD2 WCM. 080412	55	40	60	227	110	157	70			
GUD 56XD2 WCM. 080412	56	40	60	230	112	160	70			
GUD 57XD2 WCM. 080412	57	40	60	232	114	162	70			
GUD 58XD2 WCM. 080412	58	40	60	235	116	165	70			
GUD 59XD2 WCM. 080412	59	40	60	237	118	167	70			
GUD 60XD2 WCM. 080412	60	40	60	240	120	170	70			

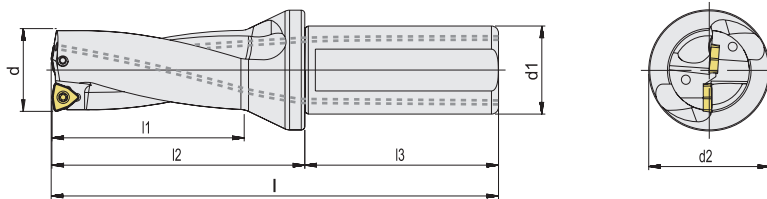

Bestellbeispiel/Ordering example: 1 Stk/pcs. GUD 60XD2 WCM. 080412

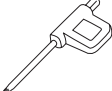

Bezeichnung Designation	Abmessungen (mm) Dimensions (mm)							Wendeplatte Insert	Ersatzteile Spare parts	
	d	d ₁	d ₂	l	l ₁	l ₂	l ₃		Spannschraube Clamping screw	Torx Schlüssel Torx key
										
GUD 16XD3 WCM. 030208	16	25	34	124	48	68	56	WCM. 030208	011008	
GUD 16.5XD3 WCM. 030208	16.5	25	34	127	51	71	56			
GUD 17XD3 WCM. 030208	17	25	34	127	51	71	56			
GUD 17.5XD3 WCM. 030208	17.5	25	34	131	54	75	56			
GUD 18XD3 WCM. 030208	18	25	34	131	54	75	56			
GUD 18.5XD3 WCM. 030208	18.5	25	34	134	57	78	56			
GUD 19XD3 WCM. 030208	19	25	34	134	57	78	56			
GUD 19.5XD3 WCM. 030208	19.5	25	34	139	60	83	56			
GUD 20XD3 WCM. 040208	20	25	34	139	60	83	56	WCM. 040208	018003	
GUD 20.5XD3 WCM. 040208	20.5	25	34	142	63	86	56			
GUD 21XD3 WCM. 040208	21	25	34	142	63	86	56			
GUD 21.5XD3 WCM. 040208	21.5	25	34	145	66	89	56			
GUD 22XD3 WCM. 040208	22	25	34	145	66	89	56			
GUD 22.5XD3 WCM. 040208	22.5	25	34	150	69	94	56			
GUD 23XD3 WCM. 040208	23	25	34	150	69	94	56			
GUD 23.5XD3 WCM. 040208	23.5	25	34	154	72	98	56			
GUD 24XD3 WCM. 050308	24	25	34	154	72	98	56	WCM. 050308	011043	
GUD 24.5XD3 WCM. 050308	24.5	25	34	158	75	102	56			
GUD 25XD3 WCM. 050308	25	25	34	158	75	102	56			
GUD 25.5XD3 WCM. 050308	25.5	25	34	161	78	105	56			
GUD 26XD3 WCM. 050308	26	25	34	161	78	105	56			
GUD 26.5XD3 WCM. 050308	26.5	25	34	164	81	108	56			
GUD 27XD3 WCM. 050308	27	25	34	164	81	108	56			
GUD 27.5XD3 WCM. 050308	27.5	25	34	168	84	112	56			
GUD 28XD3 WCM. 050308	28	25	34	168	84	112	56			
GUD 28.5XD3 WCM. 050308	28.5	25	34	171	87	115	56			
GUD 29XD3 WCM. 050308	29	25	34	171	87	115	56			
GUD 29.5XD3 WCM. 050308	29.5	25	34	177	90	121	56			

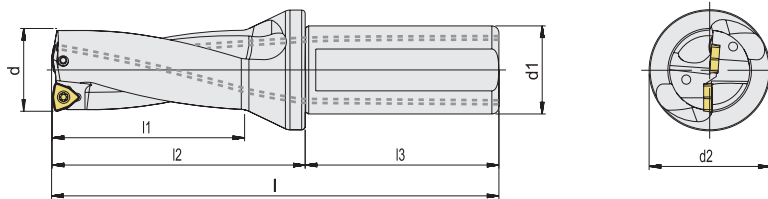
Bestellbeispiel/Ordering example: 1 Stk/pcs. GUD 29.5XD3 WCM. 050308

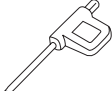

Bezeichnung Designation	Abmessungen (mm) Dimensions (mm)							Wendeplatte Insert 	Ersatzteile Spare parts	
	d	d ₁	d ₂	l	l ₁	l ₂	l ₃		Spannschraube Clamping screw 	Torx Schlüssel Torx key 
GUD 30XD3 WCM. 06T308	30	32	44	181	90	121	60	WCM. 06T308	002025	018004
GUD 31XD3 WCM. 06T308	31	32	44	185	93	125	60			
GUD 32XD3 WCM. 06T308	32	32	44	188	96	128	60			
GUD 33XD3 WCM. 06T308	33	32	44	192	99	132	60			
GUD 34XD3 WCM. 06T308	34	32	44	195	102	135	60			
GUD 35XD3 WCM. 06T308	35	32	44	199	105	139	60			
GUD 36XD3 WCM. 06T308	36	32	44	203	108	143	60			
GUD 37XD3 WCM. 06T308	37	32	44	207	111	147	60			
GUD 38XD3 WCM. 06T308	38	32	44	211	114	151	60			
GUD 39XD3 WCM. 06T308	39	32	44	214	117	154	60			
GUD 40XD3 WCM. 06T308	40	32	44	218	120	158	60			
GUD 41XD3 WCM. 06T308	41	32	44	222	123	162	60			
GUD 42XD3 WCM. 06T308	42	32	44	225	126	165	60			
GUD 43XD3 WCM. 06T308	43	32	44	229	129	169	60			
GUD 44XD3 WCM. 06T308	44	32	44	232	132	172	60			
GUD 45XD3 WCM. 080412	45	40	54	247	135	177	70			
GUD 46XD3 WCM. 080412	46	40	54	251	138	181	70			
GUD 47XD3 WCM. 080412	47	40	54	254	141	184	70			
GUD 48XD3 WCM. 080412	48	40	54	258	144	188	70			
GUD 49XD3 WCM. 080412	49	40	54	261	147	191	70			
GUD 50XD3 WCM. 080412	50	40	54	265	150	195	70			
GUD 51XD3 WCM. 080412	51	40	60	268	153	198	70			
GUD 52XD3 WCM. 080412	52	40	60	271	156	201	70			
GUD 53XD3 WCM. 080412	53	40	60	274	159	204	70			
GUD 54XD3 WCM. 080412	54	40	60	277	162	207	70			
GUD 55XD3 WCM. 080412	55	40	60	280	165	210	70			
GUD 56XD3 WCM. 080412	56	40	60	283	168	213	70			
GUD 57XD3 WCM. 080412	57	40	60	286	171	216	70			
GUD 58XD3 WCM. 080412	58	40	60	289	174	219	70			
GUD 59XD3 WCM. 080412	59	40	60	292	177	222	70			
GUD 60XD3 WCM. 080412	60	40	60	295	180	225	70			



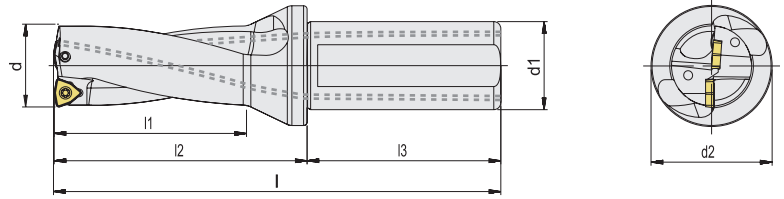



Bestellbeispiel/Ordering example: 1 Stk/pcs. GUD 60XD3 WCM. 080412

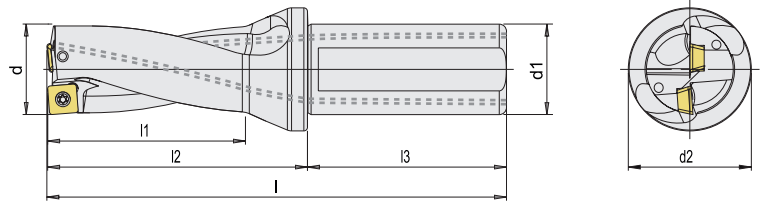

Bezeichnung Designation	Abmessungen (mm) Dimensions (mm)							Wendeplatte Insert	Ersatzteile Spare parts	
	d	d ₁	d ₂	l	l ₁	l ₂	l ₃		Spannschraube Clamping screw	Torx Schlüssel Torx key
GUD 16XD4 WCM. 030208	16	25	34	140	64	84	56	WCM. 030208		
GUD 16.5XD4 WCM. 030208	16.5	25	34	144	68	88	56			
GUD 17XD4 WCM. 030208	17	25	34	144	68	88	56			
GUD 17.5XD4 WCM. 030208	17.5	25	34	149	72	93	56			
GUD 18XD4 WCM. 030208	18	25	34	149	72	93	56			
GUD 18.5XD4 WCM. 030208	18.5	25	34	153	76	97	56			
GUD 19XD4 WCM. 030208	19	25	34	153	76	97	56			
GUD 19.5XD4 WCM. 030208	19.5	25	34	159	80	103	56			
GUD 20XD4 WCM. 040208	20	25	34	159	80	103	56	WCM. 040208	011008	018003
GUD 20.5XD4 WCM. 040208	20.5	25	34	163	84	107	56			
GUD 21XD4 WCM. 040208	21	25	34	163	84	107	56			
GUD 21.5XD4 WCM. 040208	21.5	25	34	167	88	111	56			
GUD 22XD4 WCM. 040208	22	25	34	167	88	111	56			
GUD 22.5XD4 WCM. 040208	22.5	25	34	173	92	117	56			
GUD 23XD4 WCM. 040208	23	25	34	173	92	117	56			
GUD 23.5XD4 WCM. 040208	23.5	25	34	178	96	122	56			
GUD 24XD4 WCM. 050308	24	25	34	178	96	122	56			
GUD 24.5XD4 WCM. 050308	24.5	25	34	183	100	127	56			
GUD 25XD4 WCM. 050308	25	25	34	183	100	127	56	WCM. 050308	011043	
GUD 25.5XD4 WCM. 050308	25.5	25	34	187	104	131	56			
GUD 26XD4 WCM. 050308	26	25	34	187	104	131	56			
GUD 26.5XD4 WCM. 050308	26.5	25	34	191	108	135	56			
GUD 27XD4 WCM. 050308	27	25	34	191	108	135	56			
GUD 27.5XD4 WCM. 050308	27.5	25	34	196	112	140	56			
GUD 28XD4 WCM. 050308	28	25	34	196	112	140	56			
GUD 28.5XD4 WCM. 050308	28.5	25	34	200	116	144	56			
GUD 29XD4 WCM. 050308	29	25	34	200	116	144	56			
GUD 29.5XD4 WCM. 050308	29.5	25	34	207	120	151	56			
GUD 30XD4 WCM. 06T308	30	32	44	211	120	151	60	WCM. 06T308	002025	018004
GUD 31XD4 WCM. 06T308	31	32	44	216	124	156	60			
GUD 32XD4 WCM. 06T308	32	32	44	220	128	160	60			
GUD 33XD4 WCM. 06T308	33	32	44	225	132	165	60			
GUD 34XD4 WCM. 06T308	34	32	44	229	136	169	60			
GUD 35XD4 WCM. 06T308	35	32	44	234	140	174	60			
GUD 36XD4 WCM. 06T308	36	32	44	239	144	179	60			
GUD 37XD4 WCM. 06T308	37	32	44	244	148	184	60			
GUD 38XD4 WCM. 06T308	38	32	44	249	152	189	60			
GUD 39XD4 WCM. 06T308	39	32	44	253	156	193	60			
GUD 40XD4 WCM. 06T308	40	32	44	258	160	198	60			
GUD 41XD4 WCM. 06T308	41	32	44	263	164	203	60			
GUD 42XD4 WCM. 06T308	42	32	44	267	168	207	60			
GUD 43XD4 WCM. 06T308	43	32	44	272	172	212	60			
GUD 44XD4 WCM. 06T308	44	32	44	276	176	216	60			
GUD 45XD4 WCM. 080412	45	40	54	292	180	222	70	WCM. 080412	011032	018005
GUD 46XD4 WCM. 080412	46	40	54	297	184	227	70			
GUD 47XD4 WCM. 080412	47	40	54	301	188	231	70			
GUD 48XD4 WCM. 080412	48	40	54	306	192	236	70			
GUD 49XD4 WCM. 080412	49	40	54	310	196	240	70			
GUD 50XD4 WCM. 080412	50	40	54	315	200	245	70			

Bestellbeispiel/Ordering example: 1 Stk/pcs. GUD 50XD4 WCM. 080412

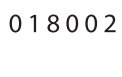

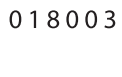
Bezeichnung Designation	Abmessungen (mm) Dimensions (mm)							Wendeplatte Insert	Ersatzteile Spare parts	
	d	d ₁	d ₂	l	l ₁	l ₂	l ₃		Spannschraube Clamping screw	Torx Schlüssel Torx key
GUD 13XD2 SPMT 050203	13	20	25	94	26	44	50			
GUD 13.5XD2 SPMT 050203	13.5	20	25	96	28	46	50			
GUD 14XD2 SPMT 050203	14	20	25	96	28	46	50			
GUD 14.5XD2 SPMT 050203	14.5	20	25	99	30	49	50			
GUD 15XD2 SPMT 050203	15	20	25	99	30	49	50			
GUD 15.5XD2 SPMT 050203	15.5	20	25	102	32	52	50			
GUD 16XD2 SPMT 060204	16	25	34	108	32	52	56			
GUD 16.5XD2 SPMT 060204	16.5	25	34	110	34	54	56			
GUD 17XD2 SPMT 060204	17	25	34	110	34	54	56			
GUD 17.5XD2 SPMT 060204	17.5	25	34	113	36	57	56			
GUD 18XD2 SPMT 060204	18	25	34	113	36	57	56			
GUD 18.5XD2 SPMT 060204	18.5	25	34	115	38	59	56			
GUD 19XD2 SPMT 060204	19	25	34	115	38	59	56			
GUD 19.5XD2 SPMT 060204	19.5	25	34	119	40	63	56			
GUD 20XD2 SPMT 060204	20	25	34	119	40	63	56			
GUD 20.5XD2 SPMT 060204	20.5	25	34	121	42	65	56			
GUD 21XD2 SPMT 060204	21	25	34	121	42	65	56			
GUD 21.5XD2 SPMT 060204	21.5	25	34	123	44	67	56			
GUD 22XD2 SPMT 070204	22	25	34	123	44	67	56			
GUD 22.5XD2 SPMT 070204	22.5	25	34	127	46	71	56			
GUD 23XD2 SPMT 070204	23	25	34	127	46	71	56			
GUD 23.5XD2 SPMT 070204	23.5	25	34	130	48	74	56			
GUD 24XD2 SPMT 070204	24	25	34	130	48	74	56			
GUD 24.5XD2 SPMT 070204	24.5	25	34	133	50	77	56			
GUD 25XD2 SPMT 070204	25	25	34	133	50	77	56			

Bestellbeispiel/Ordering example: 1 Stk/pcs. GUD 25XD2 SPMT 070204

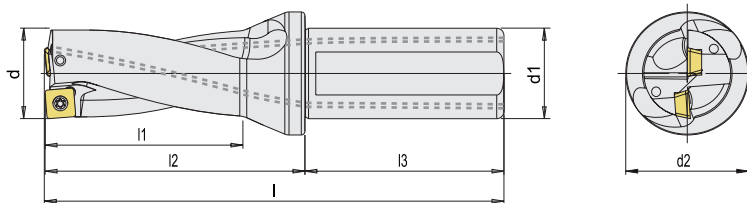

Bezeichnung Designation	Abmessungen (mm) Dimensions (mm)							Wendeplatte Insert	Ersatzteile Spare parts				
	d	d ₁	d ₂	l	l ₁	l ₂	l ₃		Spannschraube Clamping screw	Torx Schlüssel Torx key			
GUD 13XD3 SPMT 050203	13	20	25	107	39	57	50	SPMT 050203	011002	018001			
GUD 13.5XD3 SPMT 050203	13.5	20	25	110	42	60	50						
GUD 14XD3 SPMT 050203	14	20	25	110	42	60	50						
GUD 14.5XD3 SPMT 050203	14.5	20	25	113	45	63	50						
GUD 15XD3 SPMT 050203	15	20	25	113	45	63	50						
GUD 15.5XD3 SPMT 050203	15.5	20	25	118	48	68	50						
GUD 16XD3 SPMT 060204	16	25	34	124	48	68	56	SPMT 060204	011004	018002			
GUD 16.5XD3 SPMT 060204	16.5	25	34	127	51	71	56						
GUD 17XD3 SPMT 060204	17	25	34	127	51	71	56						
GUD 17.5XD3 SPMT 060204	17.5	25	34	131	54	75	56						
GUD 18XD3 SPMT 060204	18	25	34	131	54	75	56						
GUD 18.5XD3 SPMT 060204	18.5	25	34	134	57	78	56						
GUD 19XD3 SPMT 060204	19	25	34	134	57	78	56						
GUD 19.5XD3 SPMT 060204	19.5	25	34	139	60	83	56						
GUD 20XD3 SPMT 060204	20	25	34	139	60	83	56						
GUD 20.5XD3 SPMT 060204	20.5	25	34	144	63	86	56						
GUD 21XD3 SPMT 060204	21	25	34	144	63	86	56						
GUD 21.5XD3 SPMT 060204	21.5	25	34	145	66	89	56						
GUD 22XD3 SPMT 070204	22	25	34	145	66	89	56				SPMT 070204	011008	018003
GUD 22.5XD3 SPMT 070204	22.5	25	34	150	69	94	56						
GUD 23XD3 SPMT 070204	23	25	34	150	69	94	56						
GUD 23.5XD3 SPMT 070204	23.5	25	34	154	72	98	56						
GUD 24XD3 SPMT 070204	24	25	34	154	72	98	56						
GUD 24.5XD3 SPMT 070204	24.5	25	34	158	75	102	56						
GUD 25XD3 SPMT 070204	25	25	34	158	75	102	56						
GUD 13XD4 SPMT 050203	13	20	25	120	52	70	50	SPMT 050203	011002	018001			
GUD 14XD4 SPMT 050203	14	20	25	124	56	74	50						
GUD 15XD4 SPMT 050203	15	20	25	128	60	78	50						
GUD 16XD4 SPMT 060204	16	25	34	140	64	84	56	SPMT 060204	011004	018002			
GUD 17XD4 SPMT 060204	17	25	34	144	68	88	56						
GUD 18XD4 SPMT 060204	18	25	34	149	72	93	56						
GUD 19XD4 SPMT 060204	19	25	34	153	76	97	56						
GUD 20XD4 SPMT 060204	20	25	34	159	80	103	56						
GUD 21XD4 SPMT 060204	21	25	34	163	84	107	56						
GUD 22XD4 SPMT 070204	22	25	34	167	88	111	56				SPMT 070204	011008	018003
GUD 23XD4 SPMT 070204	23	25	34	173	92	117	56						
GUD 24XD4 SPMT 070204	24	25	34	178	96	122	56						
GUD 25XD4 SPMT 070204	25	25	34	183	100	127	56						

Bestellbeispiel/Ordering example: 1 Stk/pcs. GUD 25XD4 SPMT 070204

Einschraub- und Schaftfräswerkzeuge / *Screw-in end mills*



GEM **90** - **A** **P** **10**

1 2 3 4 5

D12 - **W16** - **L100** - **Z01** - **H**

6 7 8 9 10

1 Fräswerkzeug / Milling Cutter

GFM: Eck- und Planfräsköpfe / Face milling tools
GEM: Schafffräser für Wendeplatten / Indexable end mills
GCM: Faserfräser / Chamber mills
GPM: Igelfräser / Porcupine cutters
GSM: T-Nutenfräser / T-Slot cutters
GHM: Fräser für hohe Vorschübe / High-feed milling cutters
GSDM: Scheibenfräser / Slot Disc Milling

2 Anstellwinkel / Approach angle

90° - 75° - 60° - 45°
20° - 15° - 11° - 5° - 0°

5 Länge der Schneidkante (mm)
Length of cutting edge (mm)

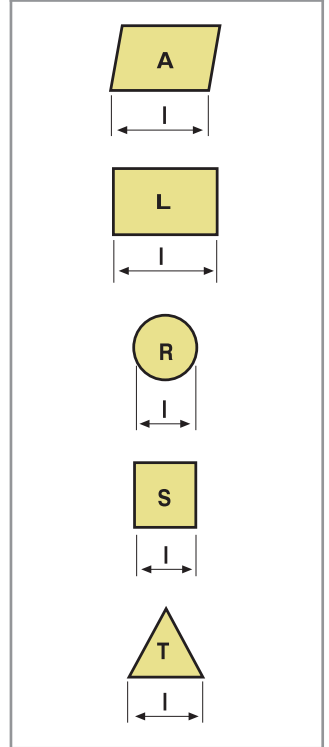

3 Grundform der Wendschneidplatte / Basic shape of indexable insert

C	D	E	K
L	R	S	T
V	W	A	B
H	M	O	P

4 Freiwinkel der Wendschneidplatte / Indexable insert clearance angle

A	B	C
D	E	F
G	N	P

6 Werkzeugdurchmesser / Tool diameter

7 Art der Montage und Durchmesser / Assembly form and diameter

A, B, C, D, : Montage gemäß ISO / Assembly according to ISO
C : Zylinder formiger Schaft / Cylindrien Shank

8 Werkzeuglänge / Tool length

9 Effektive Zähnezahl / Number of effective

10 Innere Kühlmittelzufuhr / With coolant hole

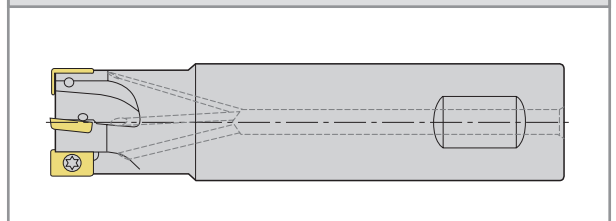

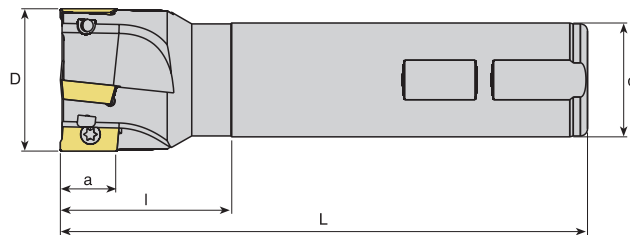



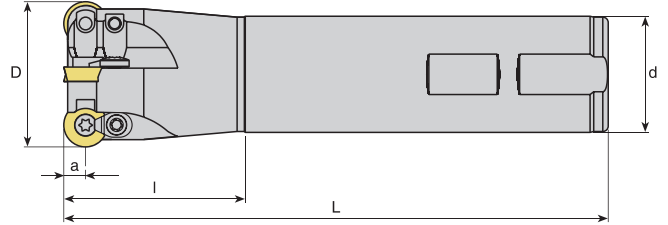

Bezeichnung Designation	Abmessungen (mm) Dimensions (mm)						Wendepplatte Insert	Ersatzteile Spare parts	
	D	Z	d	L	l	a		Spannschraube Clamping screw	Torx Schlüssel Torx key
GEM90-AP10-D12-W16-L100-Z01-H	12	1	16	100	30	10			
GEM90-AP10-D14-W16-L100-Z01-H	14	1	16	100	30	10			
GEM90-AP10-D16-W16-L100-Z02-H	16	2	16	100	30	10			
GEM90-AP10-D18-W16-L100-Z02-H	18	2	16	100	40	10			
GEM90-AP10-D20-W20-L100-Z03-H	20	3	20	100	30	10			
GEM90-AP10-D22-W20-L100-Z03-H	22	3	20	100	30	10			
GEM90-AP10-D25-W25-L100-Z03-H	25	3	25	100	30	10			
GEM90-AP10-D12-W16-L150-Z01	12	1	16	150	38	10			
GEM90-AP10-D14-W16-L150-Z01	14	1	16	150	38	10			
GEM90-AP10-D16-W16-L150-Z02	16	2	16	150	50	10			
GEM90-AP10-D16-C16-L150-Z02-H	16	2	16	150	50	10			
GEM90-AP10-D18-W16-L150-Z02	18	2	16	150	40	10			
GEM90-AP10-D20-W20-L150-Z03	20	3	20	150	50	10			
GEM90-AP10-D20-C20-L150-Z03-H	20	3	20	150	50	10			
GEM90-AP10-D21-W20-L150-Z03	21	3	20	150	50	10			
GEM90-AP10-D22-W20-L150-Z03	22	3	20	150	50	10			
GEM90-AP10-D24-W20-L150-Z03	24	3	20	150	50	10			
GEM90-AP10-D25-W25-L150-Z03	25	3	25	150	50	10			
GEM90-AP10-D32-W25-L150-Z04	32	4	25	150	50	10			
GEM90-AP10-D32-W32-L150-Z04	32	4	32	150	50	10			
GEM90-AP10-D40-W32-L150-Z05	40	5	32	150	50	10			
GEM90-AP10-D16-C16-L200-Z02	16	2	16	200	100	10			
GEM90-AP10-D20-C20-L200-Z02	20	2	20	200	100	10			
GEM90-AP10-D25-C25-L200-Z02	25	2	25	200	100	10			
GEM90-AP10-D25-C25-L200-Z03	25	3	25	200	100	10			
GEM90-AP10-D25-C25-L250-Z02	25	2	25	250	100	10			
GEM90-AP11-D16-W16-L150-Z02	16	2	16	150	50	11			
GEM90-AP11-D16-C16-L150-Z02	16	2	16	150	50	11			
GEM90-AP11-D17-C16-L150-Z02	17	2	16	150	50	11			
GEM90-AP11-D20-W20-L150-Z03	20	3	20	150	50	11			
GEM90-AP11-D20-C20-L150-Z03	20	3	20	150	50	11			
GEM90-AP11-D21-W20-L150-Z03	21	3	20	150	50	11			
GEM90-AP11-D21-W20-L150-Z03-H	21	3	20	150	50	11			
GEM90-AP11-D21-C20-L150-Z03	21	3	20	150	50	11			
GEM90-AP11-D25-W25-L150-Z03	25	3	25	150	50	11			
GEM90-AP11-D25-W25-L150-Z03-H	25	3	25	150	50	11			
GEM90-AP11-D25-C25-L150-Z03	25	3	25	150	50	11			
GEM90-AP11-D26-C25-L150-Z03	26	3	25	150	50	11			
GEM90-AP11-D32-W25-L150-Z04	32	4	25	150	50	11			
GEM90-AP11-D32-W32-L150-Z03-H	32	3	32	150	50	11			
GEM90-AP11-D32-W32-L150-Z04	32	4	32	150	50	11			
GEM90-AP11-D16-C16-L200-Z02	16	2	16	200	100	11			
GEM90-AP11-D17-C16-L200-Z02	17	2	16	200	100	11			
GEM90-AP11-D20-C20-L200-Z03	20	3	20	200	100	11			
GEM90-AP11-D21-C20-L200-Z03	21	3	20	200	100	11			

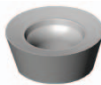

Bestellbeispiel/Ordering example: 1 Stk/pcs. GEM90 AP11 D21 C20 L200 Z03



Bezeichnung Designation	Abmessungen (mm) Dimensions (mm)						Wendepplatte Insert 	Ersatzteile Spare parts								
	D	Z	d	L	l	a		Spannschraube Clamping screw	Spannpratze Clamp	Spannschraube Clamping screw	Torx Schlüssel Torx key					
																
GEMR-RD08T2-D16-W16-L150-Z02	16	2	16	150	60	4	RD.. 08T2..	011008			018003					
GEMR-RD08T2-D20-W20-L150-Z02	20	2	20	150	60	4										
GEMR-RD0803-D16-C16-L150-Z02	16	2	16	150	60	4	RD.. 0803..	011043								
GEMR-RD0803-D16-C20-L200-Z02	16	2	20	200	60	4										
GEMRC-RD1003-D20-W20-L150-Z02	20	2	20	150	60	5	RD.. 1003..									
GEMRC-RD1003-D25-W25-L150-Z02	25	2	25	150	60	5										
GMRC-RD1003-D32-W32-L150-Z03	32	3	32	150	60	5										
GEMRC-RD1003-D40-W32-L150-Z04	40	4	32	150	50	5										
GEMRC-RD1003-D20-C20-L160-Z02	20	2	20	160	70	5										
GEMRC-RD1003-D25-C25-L160-Z02	25	2	25	160	70	5										
GEMRC-RD1003-D25-W25-L200-Z02	25	2	25	200	100	5										
GEMRC-RD1003-D25-C25-L200-Z02	25	2	25	200	100	5										
GEMRC-RD1003-D20-C20-L250-Z02	20	2	20	250	150	5										
GEMRC-RD1003-D25-C25-L250-Z02	25	2	25	250	150	5										
GEMRC-RD1003-D32-C32-L250-Z02	32	2	32	250	150	5										
GEMRC-RD1003-D40-C32-L250-Z02	40	2	32	250	50	5										
GEMRC-RD10T3-D20-W20-L150-Z02	20	2	20	150	60	5						RD.. 10T3..	011014	002022	011014	018005
GEMRC-RD10T3-D25-W25-L150-Z02	25	2	25	150	60	5										
GEMRC-RD10T3-D32-W32-L150-Z03	32	3	32	150	60	5	RD.. 12T3..									
GEMRC-RD12T3-D25-W25-L150-Z02	25	2	25	150	60	6										
GEMRC-RD12T3-D32-W32-L150-Z03	32	3	32	150	60	6										
GEMRC-RD12T3-D40-W32-L150-Z04	40	4	32	150	50	6										
GEMRC-RD12T3-D25-W25-L200-Z02	25	2	25	200	100	6										
GEMRC-RD12T3-D25-C25-L250-Z02	25	2	25	250	150	6										
GEMRC-RD12T3-D32-C32-L250-Z02	32	2	32	250	150	6										
GEMRC-RD12T3-D40-C32-L250-Z02	40	2	32	250	50	6										
GEMRC-RD12T3-D25-C25-L300-Z02	25	2	25	300	150	6										
GEMRC-RD1204-D32-C32-L160-Z03	32	3	32	160	70	6						RD.. 1204..	002028	002014	011032	
GEMRC-RD1604-D40-W32-L150-Z02	40	2	32	150	50	8	RD.. 1604..									

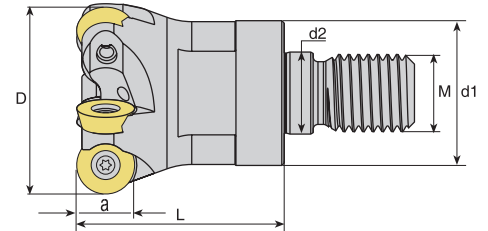

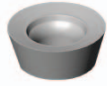
Bestellbeispiel/Ordering example: 1 Stk/pcs. GEMRC-RD1604 D40 W32 L150 Z02

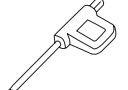

Bezeichnung Designation	Abmessungen (mm) Dimensions (mm)							Wendeplatte Insert 	Ersatzteile Spare parts				
	D	Z	d1	M	L	d2	a		Spannschraube Clamping screw 	Torx Schlüssel Torx key 			
									011008	018003			
GEMR-RD0702-D15-M08-L23-Z02-H	15	2	13	M08	23	8.5	3.5	RD.. 0702..	011008	018003			
GEMR-RD0702-D16-M08-L23-Z02-H	16	2	13	M08	23	8.5	3.5						
GEMR-RD0702-D20-M10-L30-Z04-H	20	4	18	M10	30	10.5	3.5						
GEMR-RD0702-D25-M12-L35-Z05-H	25	5	21	M12	35	17	3.5						
GEMR-RD0702-D30-M16-L42-Z05-H	30	5	29	M16	42	17	3.5						
GEMR-RD0702-D32-M16-L43-Z05-H	32	5	26	M16	43	17	3.5						
GEMR-RD0702-D35-M16-L42-Z06-H	35	6	29	M16	42	17	3.5	RD.. 1003..	011014	018005			
GEMR-RD1003-D20-M10-L30-Z02-H	20	2	18	M10	30	10.5	5						
GEMR-RD1003-D25-M12-L35-Z03-H	25	3	21	M12	35	12.5	5						
GEMR-RD1003-D30-M16-L43-Z04-H	30	4	29	M16	43	17	5						
GEMR-RD1003-D32-M16-L43-Z04-H	32	4	29	M16	43	17	5						
GEMR-RD1003-D35-M16-L43-Z04-H	35	4	29	M16	43	17	5						
GEMR-RD1003-D40-M16-L43-Z05-H	40	5	29	M16	43	17	5						
GEMR-RD1003-D42-M16-L43-Z05-H	42	5	29	M16	43	17	5						
GEMR-RD12T3-D24-M12-L35-Z02-H	24	2	21	M12	35	12.5	6				RD.. 12T3..	011014	018005
GEMR-RD12T3-D25-M12-L35-Z02-H	25	2	21	M12	35	12.5	6						
GEMR-RD12T3-D32-M16-L43-Z03-H	32	3	29	M16	43	17	6						
GEMR-RD12T3-D35-M16-L43-Z03-H	35	3	29	M16	43	17	6						
GEMR-RD12T3-D35-M16-L43-Z04-H	35	4	29	M16	43	17	6						
GEMR-RD12T3-D40-M16-L43-Z04-H	40	4	29	M16	43	17	6						
GEMR-RD12T3-D42-M16-L43-Z05-H	42	5	29	M16	43	17	6	RD.. 1604..	002028				
GEMR-RD1604-D32-M16-L43-Z02-H	32	2	29	M16	43	17	8						
GEMR-RD1604-D40-M16-L43-Z02-H	40	2	29	M16	43	17	8						
GEMR-RD1604-D42-M16-L43-Z03-H	42	3	29	M16	43	17	8						

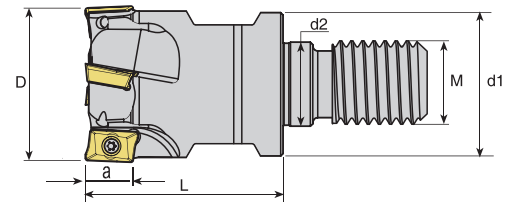

Bestellbeispiel/Ordering example: 1 Stk/pcs. GEMR RD1604 D42 M16 L43 Z03 H



Bezeichnung Designation	Abmessungen (mm) Dimensions (mm)							Wendeplatte Insert	Ersatzteile Spare parts	
	D	Z	d1	M	L	d2	a		Spannschraube Clamping screw	Torx Schlüssel Torx key
GEM90-AP10-D16-M08-L30-Z02-H	16	2	14.75	M08	30	8.5	10			
GEM90-AP10-D20-M10-L30-Z03-H	20	3	18	M10	30	10.5	10			
GEM90-AP10-D25-M12-L35-Z03-H	25	3	21	M12	35	12.5	10			
GEM90-AP10-D32-M16-L35-Z04-H	32	4	29	M16	35	17	10			
GEM90-AP10-D40-M16-L43-Z05-H	40	5	29	M16	43	17	10			
GEM90-AP10-D42-M16-L43-Z05-H	42	5	29	M16	43	17	10	AP.. 1003..	011008	018003
GEM90-AP11-D16-M08-L30-Z02-H	16	2	14.75	M08	30	8.5	11			
GEM90-AP11-D20-M10-L30-Z03-H	20	3	18	M10	30	10.5	11	AP.. 11T3..		
GEM90-AP16-D25-M12-L43-Z02-H	25	2	21	M12	43	12.5	16	AP.. 1604..	011032	018005
GEM90-AP16-D32-M16-L43-Z03-H	32	3	29	M16	43	17	16			
GEM90-AP16-D40-M16-L43-Z04-H	40	4	29	M16	43	17	16			

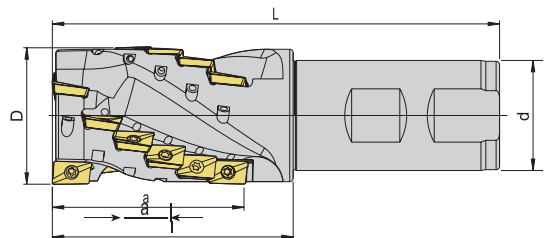

Bestellbeispiel/Ordering example: 1 Stk/pcs. GEM AP10 D16 M08 L30 Z02 H

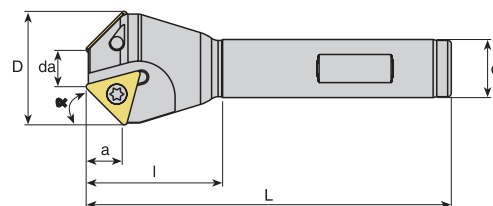

Bezeichnung Designation	Abmessungen (mm) Dimensions (mm)							Wendeplatte Insert 	Ersatzteile Spare parts	
	Z		D	d	a	L	l			Torx Schlüssel Torx key 
	TOTAL	EFFECTIVE								
GHM90-AP10-D20-W20-L087-Z06	6	2	20	20	28	87	36	AP.. 1003..	011008	018003
GHM90-AP10-D25-W25-L105-Z08	8	2	25	25	37	105	47			
GHM90-AP10-D32-W32-L115-Z15	15	3	32	32	46	115	54			
GHM90-AP10-D40-W32-L130-Z18-H	18	3	40	32	55	130	70			

Bestellbeispiel/Ordering example: 1 Stk/pcs. GHM90 AP10 D40 W32 L130 Z18 H

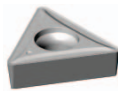

Bezeichnung Designation	Abmessungen (mm) Dimensions (mm)									Wendeplatte Insert 	Ersatzteile Spare parts			
	α	d_a	D	d	L	l	Z	a	Spannschraube Clamping screw 		Torx Schlüssel Torx key 			
GCM45 -TC09-D7X19-W16-L100-Z02	45°	7	19	16	100	25	2	6.3	TCM. 0902..	011004	018002			
GCM10 -TC16-D17X20-W16-L90-Z01	10°	17	20	16	90	30	1	15.7						
GCM15 -TC16-D17X22-W16-L90-Z01	15°	17	22	16	90	30	1	15.4						
GCM17.5 -TC16-D17X24-W16-L90-Z01	17.5°	17	24	16	90	30	1	15.2						
GCM20 -TC16-D12X20-W16-L100-Z01	20°	12	20	16	100	30	1	15						
GCM20 -TC16-D17X26-W16-L100-Z01	20°	17	26	16	100	30	1	15						
GCM22.5 -TC16-D17X28-W16-L100-Z01	22.5°	17	28	16	100	30	1	14.7						
GCM25 -TC16-D17X30-W16-L100-Z01	25°	17	30	16	100	30	1	14.5						
GCM30 -T C16-D6X20-W16-L100-Z01	30°	6	20	16	100	30	1	13.8				TCM. 16T3..	011014	018005
GCM30 -TC16-D20X35-W16-L100-Z02	30°	20	35	16	100	35	2	13.8						
GCM30 -TC16-D30X45-W20-L100-Z02	30°	30	45	20	100	40	2	13.8						
GCM45 -TC16-D5X23-W16-L100-Z01	45°	5	23	16	100	30	1	11.3						
GCM45 -TC16-D10X30-W16-L100-Z02	45°	10	30	16	100	35	2	11.3						
GCM45 -TC16-D18X37-W20-L100-Z02	45°	18	37	20	100	40	2	11.3						
GCM45 -TC16-D20X40-W20-L100-Z02	45°	20	40	20	100	40	2	11.3						
GCM45 -TC16-D30X50-W20-L100-Z02	45°	30	50	20	100	40	2	11.3						

Bestellbeispiel/Ordering example: 1 Stk/pcs. GCM45 TC16 D30X50 W20 L100 Z02

Eck- und Planmesserköpfe / Shoulder and face milling cutters



90°

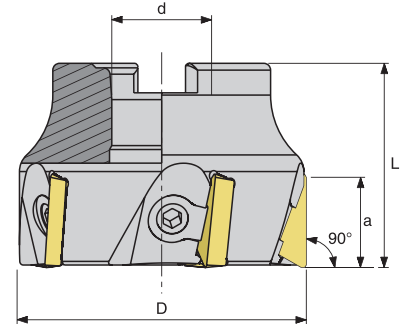



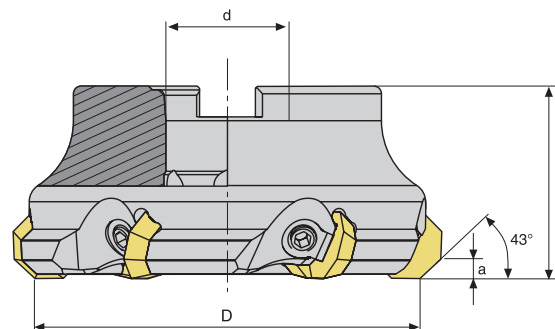

Bezeichnung Designation	Abmessungen (mm) Dimensions (mm)					Wendeplatte Insert	Ersatzteile Spare parts				
	D	z	d	L	a		Spannpratze Clamp	Spannschraube Clamping screw	Unterlage Shim	Spannschraube Clamping screw	Winkelschlüssel Allen key
GFM90C-TP16-D050-A22-Z04	50	4	22	40	12	TP.. 1603..	002019	003012			
GFM90C-TP16-D063-A22-Z06	63	6	22	45	12						
GFM90C-TP16-D080-A27-Z07	80	7	27	50	12						
GFM90C-TP16-D100-A32-Z08	100	8	32	50	12						
GFM90C-TP22-D063-A22-Z05	63	5	22	45	18	TP.. 2204..	002020	003013	017004		
GFM90C-TP22-D080-A27-Z06	80	6	27	50	18						
GFM90C-TP22-D100-A32-Z07	100	7	32	50	18						
GFM90C-TP22-D125-B40-Z08	125	8	40	63	18						
GFM90C-TP22-D160-C40-Z09	160	9	40	63	18						
GFM90C-TP22-D200-C60-Z12	200	12	60	63	18						
GFM90C-TP22-D250-C60-Z15	250	15	60	63	18						
GFM90C-TP22-D315-D60-Z18	315	18	60	63	18						
GFM90C-TP22-D063-A22-Z05	63	5	22	45	18						
GFM90C-TP22-D080-A27-Z06	80	6	27	50	18						
GFM90C-TP22-D100-A32-Z07	100	7	32	50	18	001033	004008				
GFM90C-TP22-D125-B40-Z08	125	8	40	63	18						
GFM90C-TP22-D160-C40-Z09	160	9	40	63	18						
GFM90C-TP22-D200-C60-Z12	200	12	60	63	18						
GFM90C-TP22-D250-C60-Z15	250	15	60	63	18						
GFM90C-TP22-D315-D60-Z18	315	18	60	63	18						

Bestellbeispiel/Ordering example: 1 Stk/pcs. GFM90C TP22 D315 D60 Z18





43°

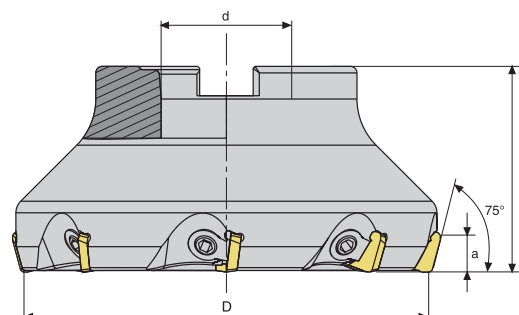

Bezeichnung Designation	Abmessungen (mm) Dimensions (mm)					Wendeplatte Insert 	Ersatzteile Spare parts		
	D	Z	d	L	a		Spannpratze Clamp	Spannschraube Clamping screw	Winkelschlüssel Allen key
									
GFM43C-OF07-D063-A22-Z04	63	4	22	40	5	OF.. 0704..	002020	003014	017004
GFM43C-OF07-D080-A27-Z05	80	5	27	50	5				
GFM43C-OF07-D100-A32-Z06	100	6	32	50	5				

75°





Bezeichnung Designation	Abmessungen (mm) Dimensions (mm)					Wendeplatte Insert 	Ersatzteile Spare parts		
	D	Z	d	L	a		Spannpratze Clamp	Spannschraube Clamping screw	Winkelschlüssel Allen key
									
GFM75C-SP12-D050-A22-Z04	50	4	22	42	8	SPKN 1203..	002019	003012	017004
GFM75C-SP12-D063-A22-Z05	63	5	22	40	8				
GFM75C-SP12-D080-A27-Z06	80	6	27	50	8				
GFM75C-SP12-D100-A32-Z07	100	7	32	50	8				
GFM75C-SP12-D125-B40-Z08	125	8	40	63	8				
GFM75C-SP12-D160-C40-Z09	160	9	40	63	8				
GFM75C-SP12-D200-C60-Z12	200	12	60	63	8				

Bestellbeispiel/Ordering example: 1 Stk/pcs. GFM75C SP12 D200 C60 Z12

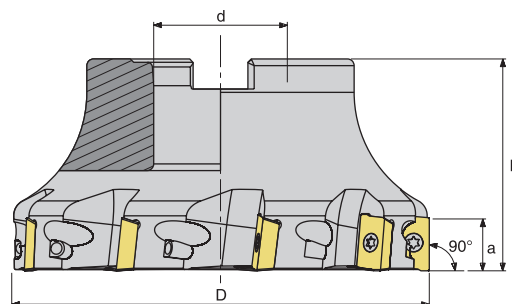
90°





Bezeichnung Designation	Abmessungen (mm) Dimensions (mm)					Wendeplatte Insert 	Ersatzteile Spare parts	
	D	Z	d	L	a		Spannschraube Clamping screw	Torx Schlüssel Torx key
								
GFM90-AP10-D040-A16-Z05-H	40	5	16	40	10	AP.. 1003..	011008	018003
GFM90-AP10-D050-A22-Z06-H	50	6	22	40	10			
GFM90-AP10-D063-A22-Z07-H	63	7	22	40	10			
GFM90-AP10-D080-A27-Z08-H	80	8	27	50	10			
GFM90-AP10-D100-A32-Z09-H	100	9	32	50	10			
GFM90-AP16-D040-A16-Z04-H	40	4	16	40	16	AP.. 1604..	011032	018005
GFM90-AP16-D050-A22-Z05-H	50	5	22	40	16			
GFM90-AP16-D063-A22-Z06-H	63	6	22	40	16			
GFM90-AP16-D080-A27-Z07-H	80	7	27	50	16			
GFM90-AP16-D100-A32-Z08-H	100	8	32	50	16			
GFM90-AP16-D125-B40-Z09	125	9	40	63	16			
GFM90-AP16-D160-C40-Z10	160	10	40	63	16			

Bestellbeispiel/Ordering example: 1 Stk/pcs. GFM90C AP16 D160 C40 Z10

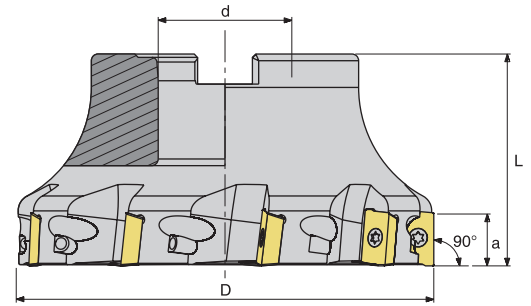

90°

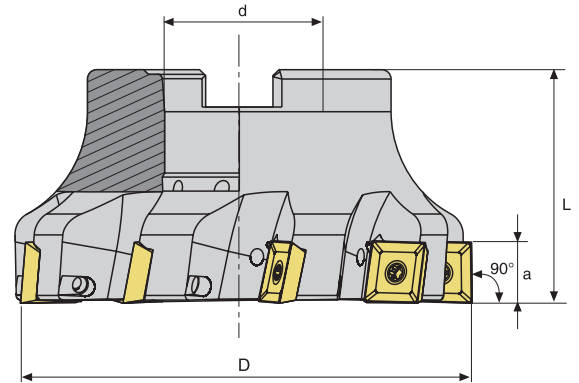

Bezeichnung Designation	Abmessungen (mm) Dimensions (mm)					Wendeplatte Insert 	Ersatzteile Spare parts	
	D	Z	d	L	a		Spannschraube Clamping screw 	Torx Schlüssel Torx key 
GFM90-AD1505-D040-A16-Z04-H	40	4	16	40	15	AD.. 1505	011032	018005
GFM90-AD1505-D050-A22-Z05-H	50	5	22	40	15			
GFM90-AD1505-D063-A22-Z06-H	63	6	22	40	15			
GFM90-AD1505-D080-A27-Z07-H	80	7	27	50	15			
GFM90-AD1505-D100-A32-Z08-H	100	8	32	50	15			
GFM90-AD1505- D125-B40-Z09	125	9	40	63	15			

90°





Bezeichnung Designation	Abmessungen (mm) Dimensions (mm)					Wendeplatte Insert 	Ersatzteile Spare parts	
	D	Z	d	L	a		Spannschraube Clamping screw 	Torx Schlüssel Torx key 
GFM90-SE12-D050-A22-Z04-H	50	4	22	40	12	SE..1203.. R290-12T3	011014	018005
GFM90-SE12-D063-A22-Z05-H	63	5	22	40	12			
GFM90-SE12-D080-A27-Z07-H	80	7	27	50	12			
GFM90-SE12-D100-A32-Z09-H	100	9	32	50	12			
GFM90-SE12-D125-B40-Z11	125	11	40	63	12			

Bestellbeispiel/Ordering example: 1 Stk/pcs. GFM90 SE12 D125 B40 Z11

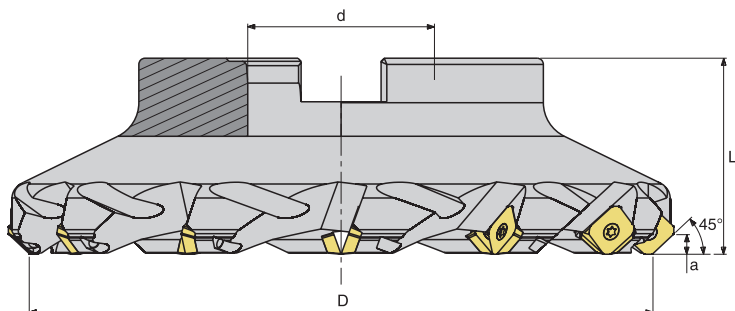

45°

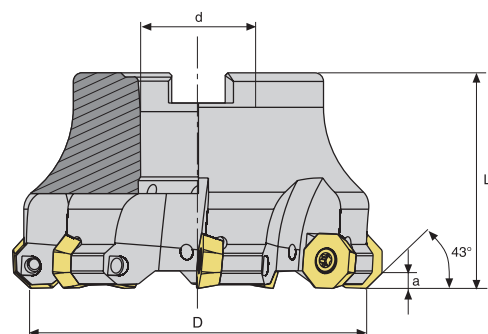

Bezeichnung Designation	Abmessungen (mm) Dimensions (mm)					Wendeplatte Insert	Ersatzteile Spare parts	
	D	Z	d	L	a		Spannschraube Clamping screw	Torx Schlüssel Torx key
GFM45-SE12-D050-A22-Z04-H	50	4	22	40	6	 SE..12T3.. R245-12T3	 011014	 018005
GFM45-SE12-D063-A22-Z05-H	63	5	22	40	6			
GFM45-SE12-D080-A27-Z06-H	80	6	27	50	6			
GFM45-SE12-D100-A32-Z07-H	100	7	32	50	6			
GFM45-SE12-D125-B40-Z08	125	8	40	63	6			
GFM45-SE12-D160-C40-Z10	160	10	40	63	6			
GFM45-SE12-D200-C60-Z12	200	12	60	63	6			

43°

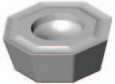

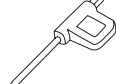

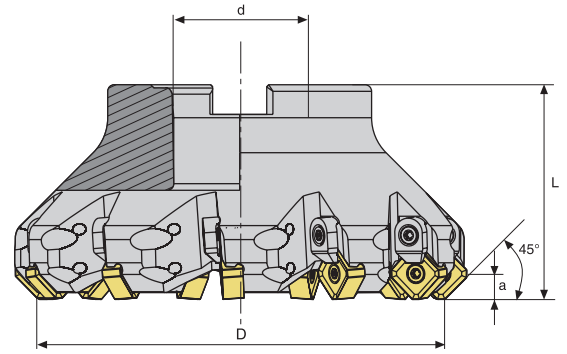

Bezeichnung Designation	Abmessungen (mm) Dimensions (mm)					Wendeplatte Insert	Ersatzteile Spare parts	
	D	Z	d	L	a		Spannschraube Clamping screw	Torx Schlüssel Torx key
GFM43-OD0504-D040-A16-Z04-H	40	4	16	40	3.5	 OD.. 0504..	 011014	 018005
GFM43-OD0504-D050-A22-Z05-H	50	5	22	40	3.5			
GFM43-OD0504-D063-A22-Z06-H	63	6	22	40	3.5			
GFM43-OD0504-D080-A27-Z07-H	80	7	27	50	3.5			
GFM43-OD0504-D100-A32-Z08-H	100	8	32	50	3.5			

Bestellbeispiel/Ordering example: 1 Stk/pcs. GFM43 OD054 D100 A32 Z08 H



45°

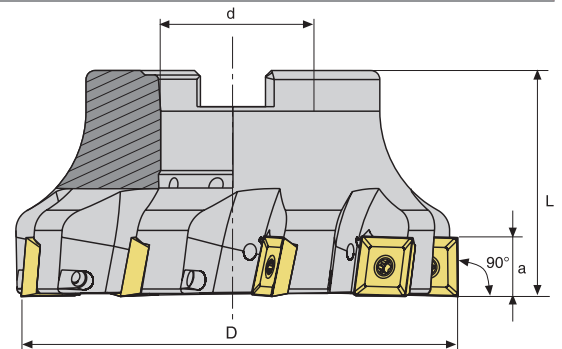

Bezeichnung Designation	Abmessungen (mm) Dimensions (mm)					Wendeplatte Insert 	Ersatzteile Spare parts			
	D	Z	d	L	a		Spannschraube Clamping screw	Spannpratze Clamp	Spannschraube Clamping screw	Torx Schlüssel Torx key
										
GFM45C-SN1206-D050-A22-Z05-H	50	5	22	40	6	SN.. 1206..	011032	002014	011032	018005
GFM45C-SN1206-D063-A22-Z07-H	63	7	22	40	6					
GFM45C-SN1206-D080-A27-Z08-H	80	8	27	50	6					
GFM45C-SN1206-D100-A32-Z10-H	100	10	32	50	6					
GFM45C-SN1206-D125-B40-Z11	125	11	40	63	6					
GFM45C-SN1206-D160-C40-Z12	160	12	40	63	6					
GFM45C-SN1206-D200-C60-Z14	200	14	60	63	6					

90°

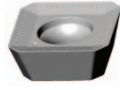

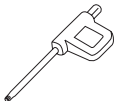

Bezeichnung Designation	Abmessungen (mm) Dimensions (mm)					Wendeplatte Insert 	Ersatzteile Spare parts	
	D	Z	d	L	a		Spannschraube Clamping screw	Torx Schlüssel Torx key
								
GFM90-SD09-D050-A22-Z05-H	50	5	22	40	9	SD.. 09M4..	011014	018005
GFM90-SD09-D063-A22-Z06-H	63	6	22	40	9			
GFM90-SD13-D050-A22-Z04-H	50	4	22	40	13	SD.. 1305..	011040	018006
GFM90-SD13-D063-A22-Z05-H	63	5	22	40	13			
GFM90-SD13-D080-A27-Z06-H	80	6	27	50	13			
GFM90-SD13-D100-A32-Z07-H	100	7	32	50	13			
GFM90-SD13-D125-B40-Z08	125	8	40	63	13			
GFM90-SD13-D160-C40-Z10	160	10	40	63	13			

Bestellbeispiel/Ordering example: 1 Stk./pcs. GFM90 SD13 D160 C40 Z10

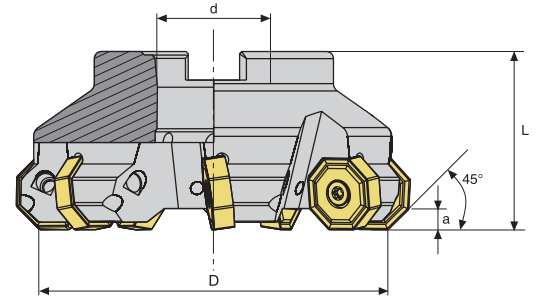

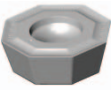
45°

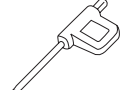

Bezeichnung Designation	Abmessungen (mm) Dimensions (mm)					Wendeplatte Insert 	Ersatzteile Spare parts	
	D	Z	d	L	a		Spannschraube Clamping screw 	Torx Schlüssel Torx key 
GFM45-ON08-D063-A22-Z05-H	63	5	22	40	4	ON..0806..	011040	018006
GFM45-ON08-D080-A27-Z06-H	80	6	27	50	4			
GFM45-ON08-D100-A32-Z07-H	100	7	32	50	4			
GFM45-ON08-D125-B40-Z08	125	8	40	63	4			
GFM45-ON08-D160-C40-Z10	160	10	40	63	4			
GFM45-ON08-D200-C60-Z12	200	12	60	63	4			

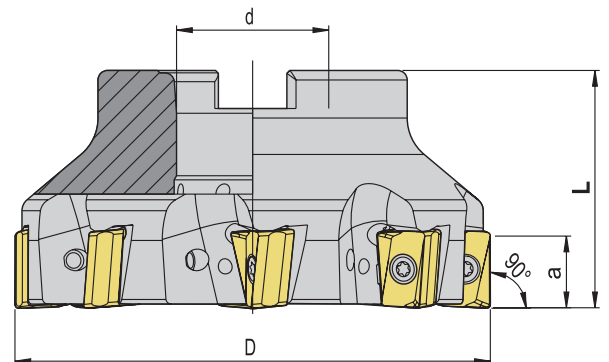
90°

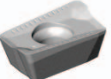



Bezeichnung Designation	Abmessungen (mm) Dimensions (mm)					Wendeplatte Insert 	Ersatzteile Spare parts	
	D	Z	d	L	a		Spannschraube Clamping screw 	Torx Schlüssel Torx key 
GFM90-AN1607-D050-A22-Z04-H	50	4	22	40	15	AN.X 1607..	011032	018005
GFM90-AN1607-D063-A22-Z06-H	63	6	22	40	15			
GFM90-AN1607-D080-A27-Z07-H	80	7	27	50	15			
GFM90-AN1607-D100-A32-Z08-H	100	8	32	50	15			

Bestellbeispiel/Ordering example: 1 Stk/pcs. GFM90 AN1607 D100 A32 Z08 H

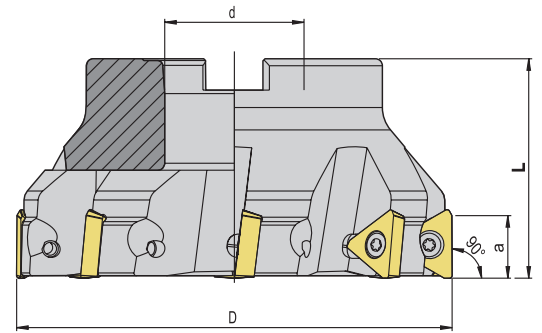

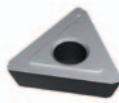
90°

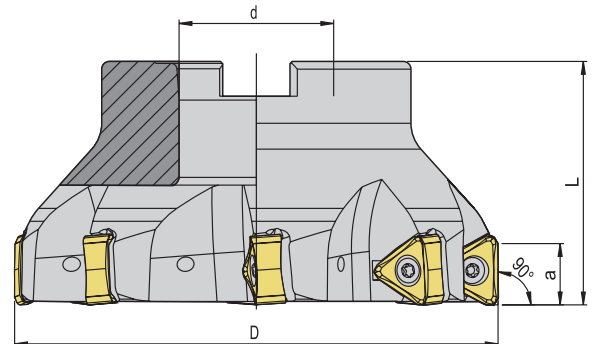

Bezeichnung Designation	Abmessungen (mm) Dimensions (mm)					Wendeplatte Insert	Ersatzteile Spare parts	
	D	Z	d	L	a		Spannschraube Clamping screw	Torx Schlüssel Torx key
GFM90-TP2205-D063-A22-Z04	63	4	22	40	18	 TPKT 2205..	 011039	 018006
GFM90-TP2205-D080-A27-Z06	80	6	27	50	18			
GFM90-TP2205-D100-A32-Z07	100	7	32	50	18			
GFM90-TP2205-D125-B40-Z08	125	8	40	63	18			
GFM90-TP2205-D160-C40-Z09	160	9	40	63	18			

90°

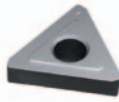







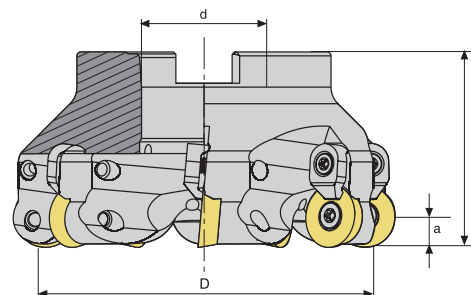







Bezeichnung Designation	Abmessungen (mm) Dimensions (mm)					Wendeplatte Insert	Ersatzteile Spare parts	
	D	Z	d	L	a		Spannschraube Clamping screw	Torx Schlüssel Torx key
GFM90-TN2207-D063-A22-Z04-H	63	4	22	40	15	 TN.X 2207..	 011039	 018006
GFM90-TN2207-D080-A27-Z05-H	80	5	27	50	15			
GFM90-TN2207-D100-B32-Z06	100	6	32	50	15			
GFM90-TN2207-D125-B40-Z08	125	8	40	63	15			

Bestellbeispiel/Ordering example: 1 Stk/pcs. GFM90 TN2207 D125 B40 Z08



45°

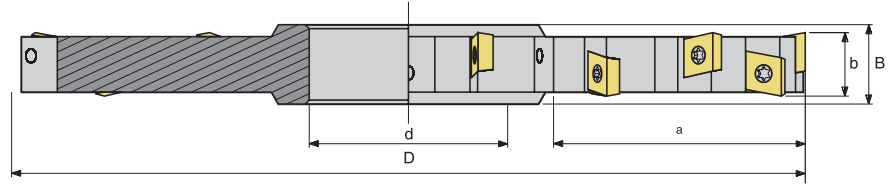

Bezeichnung Designation	Abmessungen (mm) Dimensions (mm)					Wendeplatte Insert 	Ersatzteile Spare parts			
	D	Z	d	L	a		Spannschraube Clamping screw	Spannpratze Clamp	Spannschraube Clamping screw	Torx Schlüssel Torx key
										
GFMRC-RD1003-D040-A16-Z04-H	40	4	16	40	5	RD.. 1003..				
GFMRC-RD1003-D050-A22-Z05-H	50	5	22	50	5					
GFMRC-RD1003-D063-A22-Z06-H	63	6	22	50	5					
GFMRC-RD1003-D080-A27-Z07-H	80	7	27	50	5					
GFMRC-RD1003-D100-A32-Z08-H	100	8	32	50	5					
GFMRC-RD12T3-D040-A16-Z04-H	40	4	16	40	6	RD.. 12T3..	011014	002022	011014	018005
GFMRC-RD12T3-D050-A22-Z05-H	50	5	22	50	6					
GFMRC-RD12T3-D063-A22-Z06-H	63	6	22	50	6					
GFMRC-RD12T3-D080-A27-Z07-H	80	7	27	50	6					
GFMRC-RD12T3-D100-A32-Z08-G	100	8	32	50	6					
GFMRC-RD12T3-D125-B40-Z09	125	9	40	63	6					
GFMRC-RD1204-D40-A16-Z04-H	40	4	16	40	6	RD.. 1204..				
GFMRC-RD1204-D050-A22-Z05-H	50	5	22	50	6					
GFMRC-RD1204-D052-A22-Z05-H	52	5	22	50	6					
GFMRC-RD1204-D063-A22-Z06-H	63	6	22	50	6					
GFMRC-RD1204-D080-A27-Z07-H	80	7	27	50	6					
GFMRC-RD1204-D100-A32-Z08-H	100	8	32	50	6					
GFMRC-RD1604-D052-A22-Z04-H	52	4	22	50	8	RD.. 1604..	002028	002014	011032	
GFMRC-RD1604-D063-A22-Z05-H	63	5	22	50	8					
GFMRC-RD1604-D080-A27-Z06-H	80	6	27	50	8					
GFMRC-RD1604-D100-A32-Z07-H	100	7	32	50	8					

Bestellbeispiel/Ordering example: 1 Stk/pcs. GFMRC RD1604 D100 A32 Z07 H



Bezeichnung Designation	Abmessungen (mm) Dimensions (mm)							Wendeplatte Insert 	Ersatzteile Spare parts				
	Z		D	b	a	d	B			Torx Schlüssel Torx key 			
	TOTAL	EFFECTIVE											
GSDM-CC06-D80x8 -d27-Z10	10	5	80	8	17	27	12	CC..0602..	011008	018003			
GSDM-CC06-D100x8 -d32-Z12	12	6	100	8	25	32	12						
GSDM-CC06-D125x8 -d40-Z14	14	7	125	8	35	40	12						
GSDM-CC06-D160x8 -d40-Z16	16	8	160	8	52	40	12						
GSDM-CC06-D200x8 -d40-Z18	18	9	200	8	70	40	12						
GSDM-CC06-D80x10 -d27-Z10	10	5	80	10	17	27	14						
GSDM-CC06-D100x10 -d32-Z12	12	6	100	10	25	32	14						
GSDM-CC06-D125x10 -d40-Z14	14	7	125	10	35	40	14						
GSDM-CC06-D160x10 -d40-Z16	16	8	160	10	52	40	14						
GSDM-CC06-D200x10 -d40-Z18	18	9	200	10	70	40	14						
GSDM-CC09-D80x12 -d27-Z08	8	4	80	12	17	27	16				CC..09T3..	011014	018005
GSDM-CC09-D100x12 -d32-Z10	10	5	100	12	25	32	16						
GSDM-CC09-D125x12 -d40-Z12	12	6	125	12	35	40	16						
GSDM-CC09-D160x12 -d40-Z14	14	7	160	12	52	40	16						
GSDM-CC09-D200x12 -d40-Z18	18	9	200	12	70	40	16						
GSDM-CC09-D80x14 -d27-Z08	10	5	80	14	17	27	18						
GSDM-CC09-D100x14 -d32-Z10	12	6	100	14	25	32	18						
GSDM-CC09-D125x14 -d40-Z12	14	7	125	14	35	40	18						
GSDM-CC09-D160x14 -d40-Z14	16	8	160	14	52	40	18						
GSDM-CC09-D200x14 -d40-Z18	18	9	200	14	70	40	18						
GSDM-CC12-D80x16 -d27-Z06	6	3	80	16	17	27	20	CC..1204..	011040	018006			
GSDM-CC12-D100x16 -d32-Z08	8	4	100	16	25	32	20						
GSDM-CC12-D125x16 -d40-Z10	10	5	125	16	35	40	20						
GSDM-CC12-D160x16 -d40-Z12	12	6	160	16	52	40	20						
GSDM-CC12-D200x16 -d40-Z14	14	7	200	16	70	40	20						
GSDM-CC12-D80x18 -d27-Z06	6	3	80	18	17	27	22						
GSDM-CC12-D100x18 -d32-Z08	8	4	100	18	25	32	22						
GSDM-CC12-D125x18 -d40-Z10	10	5	125	18	35	40	22						
GSDM-CC12-D160x18 -d40-Z12	12	6	160	18	52	40	22						
GSDM-CC12-D200x18 -d40-Z14	14	7	200	18	70	40	22						
GSDM-CC12-D250x18 -d40-Z16	16	8	250	18	90	40	22						
GSDM-CC12-D80x20 -d27-Z06	6	3	80	20	17	27	24						
GSDM-CC12-D100x20 -d32-Z08	8	4	100	20	25	32	24						
GSDM-CC12-D125x20 -d40-Z10	10	5	125	20	35	40	24						
GSDM-CC12-D160x20 -d40-Z12	12	6	160	20	52	40	24						
GSDM-CC12-D200x20 -d40-Z14	14	7	200	20	70	40	24						
GSDM-CC12-D250x20 -d40-Z16	16	8	250	20	90	40	24						

Bestellbeispiel/Ordering example: 1 Stk/pcs. GSDM CC12 D250x20 d40 Z16

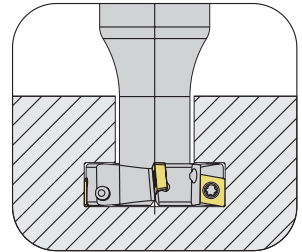
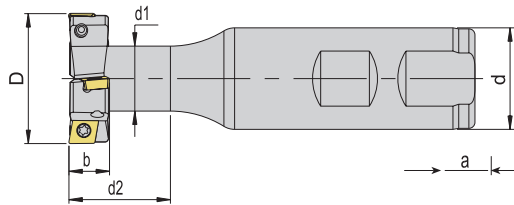
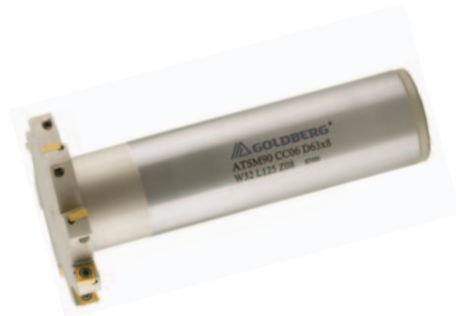

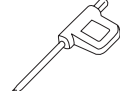
Bezeichnung Designation	Abmessungen (mm) Dimensions (mm)								Wendeplatte Insert	Ersatzteile Spare parts	
	Z		D	b	d	L	d1	d2		 Spannschraube Clamping screw	 Torx Schlüssel Torx key
	TOTAL	EFFECTIVE									
GTSM90-CC06-D17X8- W16-L85- Z02	2	1	17	8	16	85	10	16	CC.. 0602..	011008	018003
GTSM90-CC06-D32X8- W25-L100-Z04	4	2	32	8	25	100	16	23			
GTSM90-CC06-D63X8- W32-L125-Z08	8	4	63	8	32	125	31.5	30			
GTSM90-CC06-D18X9- W16-L90- Z02	2	1	18	9	16	90	10	16			
GTSM90-CC06-D20X9- W16-L85- Z04	4	2	20	9	16	85	10	16			
GTSM90-CC06-D23X10- W20-L90- Z04	4	2	23	10	20	90	12	25			
GTSM90-CC06-D32X10 -W25-L100-Z04	4	2	32	10	25	100	16	25			
GTSM90-CC06-D45X10 -W32-L120-Z06	6	3	45	10	32	120	20	25			
GTSM90-CC06-D25X11 -W25-L100-Z04	4	2	25	11	25	100	13	20			
GTSM90-CC09-D30X12 -W25-L100-Z04	4	2	30	12	25	100	16	25	CC.. 09T3..	011014	018005
GTSM90-CC09-D32X12 -W25-L100-Z04	4	2	32	12	25	100	16	25			
GTSM90-CC09-D32X14 -W25-L100-Z04	4	2	32	14	25	100	16	25			
GTSM90-CC09-D37X16 -W32-L120-Z04	4	2	37	16	32	120	17	30			
GTSM90-CC09-D42X17 -W32-L120-Z04	4	2	42	17	32	120	19	30			
GTSM90-CC09-D40X18 -W32-L120-Z04	4	2	40	18	32	120	19	30			
GTSM90-CC12-D47X20 -W32-L120-Z04	4	2	47	20	32	120	25	45	CC.. 1204..	011040	018006
GTSM90-CC12-D52X21 -W32-L120-Z04	4	2	52	21	32	120	25	45			
GTSM90-CC12-D50X22 -W32-L120-Z04	4	2	50	22	32	120	25	45			
GTSM90-CC12-D55X22 -W32-L120-Z04	4	2	55	22	32	120	25	45			

Bestellbeispiel/Ordering example: 1 Stk./pcs. GTSM90 CC06 D17X8 W16 L85 Z02

 **GOLDBERG®**
innovation. precision. performance.



**Precision reached
with best technology.**

www.goldberg-tech.de